

MANITOBA HYDRO

**TRANSMISSION SYSTEM
INTERCONNECTION REQUIREMENTS**



April 2009
Version 2



LEGISLATIVE AUTHORITY

Section 15(5) of *The Manitoba Hydro Act* authorizes Manitoba Hydro to set, coordinate and enforce standards and rules for the security, reliability and quality control of the transmission and distribution facilities of any person, other than Manitoba Hydro, whose facilities are interconnected with the transmission and distribution lines of Manitoba Hydro. Pursuant to Section 10 of *Regulation 186/90 – Electric Power Terms and Conditions and Supply*, Manitoba Hydro is authorized to determine the voltage, frequency, phasing and other characteristics of power, the determination of which is final and binding on the user. Pursuant to this legislative authority, Manitoba Hydro has established the following Transmission System interconnection requirements for facilities interconnected to the MH TRANSMISSION SYSTEM.

PLANNING STANDARDS

Compliance with the technical requirements described in this document will ensure that facilities interconnected to the MH TRANSMISSION SYSTEM will comply with the planning criteria of MH. The interconnected facilities will also comply with the reliability requirements of the Midwest Reliability Organization (or its successor organization) and the North American Electric Reliability Corporation, NERC, (or its successor organization) Reliability Standards [1]. Facility Owners/Operators are responsible to ensure that they are compliant with NERC and other applicable Reliability Standards.

IMPORTANT

THIS MATERIAL IS THE EXCLUSIVE PROPERTY
OF MANITOBA HYDRO. ANY RELEASE,
REPRODUCTION, OR OTHER USE THEREOF,
WITHOUT THE WRITTEN CONSENT OF
MANITOBA HYDRO, IS STRICTLY PROHIBITED.

DOCUMENT CHANGE HISTORY

Version	Date	Signing Authority	Brief Description of Change/Review
0	2003 12 12	David Jacobson	Initial Publication.
1	2007 07 12	Steve Shelemy	<p>Major revision including updated or new material.</p> <p>Section 1.1 Definitions: (updated and new material) 1.1.16 Emergency Operating Guides 1.1.17 Interconnection System Upgrades 1.1.18 IOA 1.1.19 MAPP 1.1.27 MRO 1.1.36 Operating Procedures 1.1.39 Standing Operating Guides 1.1.41 Temporary Operating Guides. 1.1.45 Wind Data. 1.3 Applicability 1.5 Procedure for Interconnecting and Modifying Existing Facilities 1.6 Inspection and Review</p> <p>Section 2 System Information and Design Practices: (updated and new material) 2.1 Reliability Criteria 2.3 Voltage Variations 2.6.3 System Damping 2.6.5 Monitoring Facilities 2.10 Insulation Levels 2.12 Communication Systems 2.13 Automatic Generation Controls 2.15 Station Battery 2.16 Operating Studies and Procedures 2.17 Modelling Data</p> <p>Section 3 Generator Interconnection Requirements: (updated and new material) 3.1 Interconnection Location and Voltage Level 3.2 Sealing of Technical Reports, Drawings, Memos, etc. 3.3 Operating Procedures 3.4 Reactive Power Requirements 3.5 Dynamic Reactive Power Requirements 3.6 Voltage Variations 3.7 Frequency Variations 3.9.5 Power Ramp Rates 3.9.6 Maximum Power Limit 3.9.8 Automatic Generation Control (AGC) 3.10 Synchronizing Facilities 3.11 Special Protection Systems (SPS) or Remedial Action Schemes (RAS) 3.12 Black Start Capability 3.13.1 Power Quality 3.14 Protection Requirements 3.16.1 General (Revenue Metering) 3.16.2 Accuracy 3.16.7 Meter Seals 3.16.8 Meter Tests 3.16.9 Security Audit 3.17 Telemetering, Metering, and Supervisory Control and Data Acquisition (SCADA) 3.29 Modelling Data and Special Tests 3.34 Special Interconnection Requirements 3.35 Generation Forecasting</p> <p>Section 4 Wind Generator Interconnection Requirements: (new section).</p>

			<p>Section 5 Customer Load Interconnection Requirements: (updated and new material) 5.2 Sealing of Technical Reports, Drawings, Memos, etc. 5.6 Power Quality 5.8 Underfrequency Load Shed (UFLS) 5.12.1 General (Revenue Metering) . 5.12.2 Accuracy 5.12.7 Meter Seals 5.12.8 Meter Tests 5.12.9 Security Audit 5.16 Insulation Levels 5.18 Lightning (Surge) Protection 5.19 Safety 5.20 Design Standards 5.23 Isolation 5.24 Transformer Connections 5.25 Verification of Load Demand Characteristics 5.26 Testing and Maintenance Coordination 5.29 Notification of New or Modified Facilities</p> <p>Section 6 Transmission Owner Interconnection Requirements: (updated and new material) 6.2 Sealing of Technical Reports, Drawings, Memos, etc. 6.12.1 General (Revenue Metering) 6.12.2 Accuracy 6.12.7 Meter Seals 6.12.8 Meter Tests 6.12.9 Security Audit</p> <p>Section 8 Figures (new)</p> <p>Section 9 References (updated)</p>
2	2009 04 17	Steve Shelemy	<p>Update Document Change History. Add Section 2.18 Equipment Ratings. Modify Sections: 3.32, 5.28, 6.25 Coordinated Joint Studies. 3.33, 5.29, 6.26 Notification of New or Modified Facilities.</p>

MANITOBA HYDRO

TRANSMISSION SYSTEM INTERCONNECTION REQUIREMENTS

TABLE OF CONTENTS

	Page
1.0 INTRODUCTION.....	9
1.1 DEFINITIONS	9
1.2 SCOPE AND REVISIONS	16
1.3 APPLICABILITY	16
1.4 OBJECTIVES	17
1.5 PROCEDURE FOR INTERCONNECTING OR MODIFYING EXISTING FACILITIES	17
1.6 INSPECTION AND REVIEW.....	17
1.7 FAILURE TO COMPLY	18
2.0 MH TRANSMISSION SYSTEM - SYSTEM INFORMATION AND DESIGN PRACTICE	19
2.1 RELIABILITY CRITERIA.....	19
2.2 VOLTAGE LEVELS	19
2.3 VOLTAGE VARIATIONS.....	19
2.4 FREQUENCY AND FREQUENCY VARIATIONS.....	20
2.5 POWER QUALITY	20
2.6 SYSTEM PROTECTION AND CONTROL	20
2.6.1 <i>Protection System Implementation</i>	<i>20</i>
2.6.2 <i>Typical Fault Clearing Times</i>	<i>20</i>
2.6.3 <i>System Damping</i>	<i>21</i>
2.6.4 <i>Transmission Line Protection Systems</i>	<i>21</i>
2.6.5 <i>Monitoring Facilities</i>	<i>22</i>
2.7 UNDERFREQUENCY LOAD SHED (UFLS).....	23
2.8 UNDERVOLTAGE LOAD SHED (UVLS)	23
2.9 SYSTEM GROUNDING	23
2.10 INSULATION LEVELS	23
2.11 SHORT CIRCUIT LEVELS.....	23
2.12 COMMUNICATION SYSTEMS	24
2.13 AUTOMATIC GENERATION CONTROL	24
2.14 TRANSFORMER WINDING CONFIGURATIONS.....	24
2.15 STATION BATTERY	25
2.16 OPERATING STUDIES AND PROCEDURES	25
2.17 MODELLING DATA	25
2.18 EQUIPMENT RATINGS	26
3.0 GENERATOR INTERCONNECTION REQUIREMENTS.....	27
3.1 INTERCONNECTION LOCATION AND VOLTAGE LEVEL.....	27
3.2 SEALING OF TECHNICAL REPORTS, DRAWINGS, MEMOS, ETC	27
3.3 OPERATING PROCEDURES	27
3.4 REACTIVE POWER REQUIREMENTS	27
3.5 DYNAMIC POWER REQUIREMENTS	28
3.6 VOLTAGE VARIATIONS.....	28
3.7 FREQUENCY VARIATIONS.....	28
3.8 INERTIA CONSTANT (H)	29

3.9	SYNCHRONOUS GENERATOR CONTROLS	29
3.9.1	Speed Governor	29
3.9.2	Excitation System.....	30
3.9.3	Automatic Voltage Regulator (AVR).....	31
3.9.4	Joint Var Control.....	31
3.9.5	Power Ramp Rates.....	31
3.9.6	Maximum Power Limit.....	31
3.9.7	Power System Stabilizer (PSS).....	32
3.9.8	Automatic Generation Control (AGC).....	32
3.10	SYNCHRONIZING FACILITIES	32
3.11	SPECIAL PROTECTION SYSTEMS (SPS) OR REMEDIAL ACTION SCHEMES (RAS).....	32
3.12	BLACK START CAPABILITY	33
3.13	POWER QUALITY	33
3.13.1	Power Quality	33
3.13.2	Resonance and Self-Excitation.....	34
3.14	PROTECTION REQUIREMENTS	34
3.15	COMMUNICATIONS.....	36
3.16	REVENUE METERING.....	36
3.16.1	General	36
3.16.2	Accuracy	37
3.16.3	Metering Configuration	37
3.16.4	Energy Losses	37
3.16.5	Meter Reading.....	37
3.16.6	Check Metering.....	38
3.16.7	Meter Seals.....	38
3.16.8	Meter Tests.....	38
3.16.9	Security Audit.....	38
3.17	TELEMETERING, METERING, AND SUPERVISORY CONTROL AND DATA ACQUISITION(SCADA).....	38
3.18	DISTURBANCE MONITORING	40
3.19	INSULATION LEVELS	41
3.20	SHORT CIRCUIT LEVELS	41
3.21	GROUNDING	41
3.22	LIGHTNING (SURGE) PROTECTION.....	41
3.23	SAFETY	41
3.24	DESIGN STANDARDS	41
3.25	ENVIRONMENTAL CONDITIONS	42
3.26	CLEARANCES AND ACCESS.....	42
3.27	ISOLATION.....	42
3.28	TRANSFORMER CONNECTION	42
3.29	MODELLING DATA AND SPECIAL TESTS.....	43
3.30	TESTING AND MAINTENANCE COORDINATION	43
3.31	INSPECTION REQUIREMENTS	43
3.23	COORDINATED JOINT STUDIES	43
3.33	NOTIFICATION OF NEW OR MODIFIED FACILITIES	43
3.34	SPECIAL INTERCONNECTION REQUIREMENTS.....	44
3.35	GENERATION FORECASTING.....	44
4.0	WIND GENERATOR INTERCONNECTION REQUIREMENTS	45
4.1	VOLTAGE TOLERANCE	45
4.2	FREQUENCY TOLERANCE	45
4.3	POWER CONTROL	45
4.4	REACTIVE POWER CAPABILITY/CONTROL	45
4.5	INDUCTION GENERATOR CONTROLS	46
4.5.1	Voltage Regulation	46

4.5.2	<i>Frequency Response</i>	46
4.5.3	<i>Power Ramp Rates</i>	47
4.5.4	<i>Other Controls</i>	47
4.6	LOW VOLTAGE RIDE-THROUGH	47
4.7	POST DISTURBANCE RECOVERY.....	48
4.8	SYNCHRONIZING FACILITIES	48
4.9	MODELLING DATA	49
4.10	MODELLING DATA VERIFICATION.....	50
4.11	SPECIAL COMMISSIONING TESTS.....	52
4.12	POWER QUALITY	52
4.13	OPERATIONAL MONITORING AND WIND DATA	53
4.14	PROTECTIVE EQUIPMENT AND RELAYING SYSTEM REQUIREMENTS.....	55
4.15	CLEARANCES AND ACCESS.....	55
4.16	UNDERGROUND CABLES	55
4.17	GENERATOR TAPPING	55
5.0	CUSTOMER LOAD INTERCONNECTION REQUIREMENTS.....	56
5.1	INTERCONNECTION LOCATION AND VOLTAGE LEVEL.....	56
5.2	SEALING OF TECHNICAL REPORTS, DRAWINGS, MEMOS, ETC.	56
5.3	OPERATING PROCEDURES	56
5.4	VOLTAGE REGULATION AND POWER FACTOR REQUIREMENTS	56
5.5	VOLTAGE AND FREQUENCY AT POINT(S) OF INTERCONNECTION	56
5.6	POWER QUALITY	57
5.6.1	<i>Power Quality</i>	57
5.6.2	<i>Resonance and self-excitation</i>	57
5.7	PROTECTION REQUIREMENTS	57
5.8	UNDERFREQUENCY LOAD SHED (UFLS).....	59
5.9	UNDERVOLTAGE LOAD SHED (UVLS)	59
5.10	LOAD RESTORATION	60
5.11	LINE AUTO-RECLOSING	60
5.12	REVENUE METERING.....	60
5.12.1	<i>General</i>	60
5.12.2	<i>Accuracy</i>	61
5.12.3	<i>Metering Configuration</i>	61
5.12.4	<i>Energy Losses</i>	61
5.12.5	<i>Meter Reading</i>	62
5.12.6	<i>Check Metering</i>	62
5.12.7	<i>Meter Seals</i>	62
5.12.8	<i>Meter Tests</i>	62
5.12.9	<i>Security Audit</i>	62
5.13	TELEMETERING AND METERING, SUPERVISORY CONTROL AND DATA ACQUISITION (SCADA).....	62
5.14	DISTURBANCE MONITORING	63
5.15	COMMUNICATIONS	63
5.16	INSULATION LEVELS	63
5.17	SHORT CIRCUIT LEVELS.....	64
5.18	LIGHTNING (SURGE) PROTECTION.....	64
5.19	SAFETY	64
5.20	DESIGN STANDARDS	64
5.21	ENVIRONMENTAL CONDITIONS	64
5.22	CLEARANCES AND ACCESS.....	64
5.23	ISOLATION.....	64
5.24	TRANSFORMER CONNECTION	65
5.25	VERIFICATION OF LOAD DEMAND CHARACTERISTIC MODELLING	65
5.26	TESTING AND MAINTENANCE COORDINATION	65

5.27	INSPECTION REQUIREMENTS	66
5.28	COORDINATED JOINT STUDIES	66
5.29	NOTIFICATION OF NEW OR MODIFIED FACILITIES	66
6.0	TRANSMISSION LINE OWNER INTERCONNECTION REQUIREMENTS	67
6.1	INTERCONNECTION LOCATION AND VOLTAGE LEVEL	67
6.2	SEALING OF TECHNICAL REPORTS, DRAWINGS, MEMOS, ETC.	67
6.3	OPERATING PROCEDURES	67
6.4	REACTIVE POWER REQUIREMENTS	67
6.5	VOLTAGE AND FREQUENCY AT POINT(S) OF INTERCONNECTION	68
6.6	TRANSMISSION LINE DESIGN CRITERIA	68
6.6.2	<i>Electrical Loading Design Criteria</i>	68
6.6.3	<i>External Electrical Effects</i>	68
6.6.4	<i>Shield Wires</i>	68
6.7	POWER QUALITY	68
6.7.1	<i>Power Quality</i>	68
6.7.2	<i>Resonance and self-excitation</i>	69
6.8	PROTECTION SYSTEMS	69
6.9	RECLOSING	70
6.10	SYNCHRONIZING	71
6.11	SPECIAL PROTECTION SYSTEMS (SPS) OR REMEDIAL ACTION SCHEMES (RAS)	71
6.12	REVENUE METERING	71
6.12.1	<i>General</i>	71
6.12.2	<i>Accuracy</i>	72
6.12.3	<i>Metering Configuration</i>	72
6.12.4	<i>Energy Losses</i>	72
6.12.5	<i>Meter Reading</i>	72
6.12.6	<i>Check Metering</i>	73
6.12.7	<i>Meter Seals</i>	73
6.12.8	<i>Meter Tests</i>	73
6.12.9	<i>Security Audit</i>	73
6.13	TELEMETERING, METERING, SUPERVISORY CONTROL AND DATA ACQUISITION (SCADA)	74
6.14	DISTURBANCE MONITORING	74
6.15	COMMUNICATIONS	75
6.16	INSULATION LEVELS	75
6.17	SHORT CIRCUIT LEVELS	75
6.18	SAFETY	75
6.19	ENVIRONMENTAL CONDITIONS	76
6.20	CLEARANCES AND ACCESS	76
6.21	ISOLATION	76
6.22	TESTING AND MAINTENANCE COORDINATION	76
6.23	PROTECTION SYSTEM MAINTENANCE AND TESTING	76
6.24	INSPECTION REQUIREMENTS	76
6.25	COORDINATED JOINT STUDIES	77
6.26	NOTIFICATION OF NEW OR MODIFIED FACILITIES	77
7.0	TECHNICAL DATA TO BE PROVIDED BY THE FACILITY OWNER	78
7.1	GENERATOR FACILITY TECHNICAL DATA	78
7.1.1	<i>Thermal Turbine-Generator Mechanical Data (100 MVA or larger unit)</i>	79
7.1.2	<i>Synchronous Generator Data</i>	80
7.1.3	<i>Induction Generator Data</i>	81
7.1.4	<i>Non-Standard Generator with Power Electronic Interface Data</i>	81
7.2	CUSTOMER LOAD FACILITY TECHNICAL DATA	82
7.3	TRANSMISSION LINE OWNER INTERCONNECTION FACILITY TECHNICAL DATA	84

8.0 FIGURES.....86

9.0 REFERENCES.....92

MANITOBA HYDRO

TRANSMISSION SYSTEM INTERCONNECTION REQUIREMENTS

1.0 INTRODUCTION

MH has established these Transmission System interconnection requirements to identify the technical requirements for interconnection of Facility(ies) to the MH Transmission System. This document is intended to provide Facility Owners wishing to interconnect with the MH Transmission System with MH reliability requirements and design practices that can be used to assist in the planning and design of the Facility.

1.1 Definitions

This section defines the terms used in this document. The definitions used herein may be different from definitions of similar terms used in other documents *and are exclusive to this document. The definitions used herein are not to be used in any fashion to interpret, modify or explain in any way a definition of a similar term in any other agreement.*

- 1.1.1 **BLACK START CAPABILITY:** The ability of a generating unit or station to go from a shutdown condition to an operating condition and start delivering power without assistance from the electric system.
- 1.1.2 **CUSTOMER LOAD:** shall mean a person or entity proposing to interconnect its CUSTOMER LOAD FACILITY(IES) to the MH TRANSMISSION SYSTEM or to make a SUBSTANTIAL MODIFICATION to an existing CUSTOMER LOAD FACILITY(IES) connected to the MH TRANSMISSION SYSTEM.
- 1.1.3 **CUSTOMER LOAD FACILITY(IES):** A facility with electrical load that normally receives power from the MH TRANSMISSION SYSTEM (i.e. NATIVE LOAD). The CUSTOMER LOAD FACILITY(IES) may include its own generation, reactive power compensation, transformation and plant distribution.
- 1.1.4 **CUSTOMER LOAD INTERCONNECTION FACILITY(IES):** All facilities and equipment owned and/or controlled, operated and maintained by the CUSTOMER LOAD, including any modifications, additions, or upgrades made to such facilities and equipment, that are necessary to physically and electrically interconnect the CUSTOMER LOAD FACILITY(IES) to the POINT(S) OF INTERCONNECTION.
- 1.1.5 **EMERGENCY CONDITION(S):** Any condition or situation that is likely to endanger life or property, violate any environmental law; or is likely to cause a material adverse effect on the security of, or damage to the FACILITY, the INTERCONNECTION FACILITY(IES), the MH TRANSMISSION SYSTEM or the transmission system of other electric utilities. Any

condition or situation that results from lack of sufficient generating capacity to meet load requirements or that results from economic conditions shall not constitute an EMERGENCY CONDITION, unless one of the enumerated conditions or situations identified in this definition also exists.

- 1.1.6 EMERGENCY OPERATING GUIDES are developed due to unforeseen real time system conditions or problems observed in the next day study and are effective only during the EMERGENCY CONDITION. These guides may not include formal documentation during the EMERGENCY CONDITIONS if time does not permit.
- 1.1.7 FACILITY(IES): CUSTOMER LOAD FACILITY(IES) or GENERATOR FACILITY(IES) or TRANSMISSION LINE OWNER FACILITY(IES), as applicable.
- 1.1.8 FACILITY OWNER(S): A FACILITY OWNER is a GENERATOR, CUSTOMER LOAD or TRANSMISSION LINE OWNER interconnecting or interconnected to the MH TRANSMISSION SYSTEM.
- 1.1.9 GENERATOR: shall mean a person or entity proposing to interconnect its GENERATOR FACILITY(IES) to the MH TRANSMISSION SYSTEM or to make a SUBSTANTIAL MODIFICATION to its existing GENERATOR FACILITY(IES) connected to the MH TRANSMISSION SYSTEM.
- 1.1.10 GENERATOR FACILITY(IES): A facility that generates electrical power and delivers capacity and energy to the MH TRANSMISSION SYSTEM.
- 1.1.11 GENERATOR INTERCONNECTION FACILITY(IES): All facilities and equipment owned and/or controlled, operated and maintained by the GENERATOR, including any modifications, additions, or upgrades made to such facilities and equipment, that are necessary to physically and electrically interconnect the GENERATOR FACILITY(IES) to the POINT(S) OF INTERCONNECTION.
- 1.1.12 GOOD UTILITY PRACTICE: Any of the practices, methods and acts engaged in or approved by a significant portion of the electric utility industry during the relevant time period, or any of the practices, methods and acts which, in the exercise of reasonable judgement in light of the facts known at the time the decision was made, could have been expected to accomplish the desired result at a reasonable cost consistent with good business practices, reliability, safety and expedition. GOOD UTILITY PRACTICE is not intended to be limited to the optimum practice, method, or act to the exclusion of all others, but rather to be acceptable practices, methods or acts generally accepted in the region.
- 1.1.13 INTERCONNECTION FACILITY(IES): CUSTOMER LOAD INTERCONNECTION FACILITY(IES) or GENERATOR INTERCONNECTION FACILITY(IES) or TRANSMISSION LINE OWNER INTERCONNECTION FACILITY(IES) and MH INTERCONNECTION FACILITY(IES) that collectively include all facilities and equipment between the FACILITY(IES) and the MH TRANSMISSION SYSTEM, including any modifications, additions or upgrades that are

necessary to physically and electrically interconnect the FACILITY(IES) to the MH TRANSMISSION SYSTEM. INTERCONNECTION FACILITY(IES) shall not include INTERCONNECTION SYSTEM UPGRADES.

- 1.1.14 INTERCONNECTION STUDIES: Studies to determine the impacts and requirements for interconnection of the FACILITY(IES) to the MH TRANSMISSION SYSTEM, including any INTERCONNECTION SYSTEM UPGRADES, as needed to comply with the technical requirements of this document and GOOD UTILITY PRACTICE. INTERCONNECTION STUDIES include an INTERCONNECTION EVALUATION STUDY and an INTERCONNECTION FACILITIES STUDY.
- 1.1.15 INTERCONNECTION EVALUATION STUDY: A transmission study conducted in accordance with GOOD UTILITY PRACTICE and applicable MH and regional reliability standards and practices to assess the impact of interconnecting the FACILITY(IES) on the reliability of the MH TRANSMISSION SYSTEM and adjacent transmission systems. The study is conducted in two phases. Phase 1 consists of power flow analysis. Phase 2 consists of short circuit and stability analysis.
- 1.1.16 INTERCONNECTION FACILITIES STUDY: A transmission study conducted in accordance with GOOD UTILITY PRACTICE and applicable MH and regional reliability standards and practices to determine the work required to effect the physical and electrical connection of the FACILITY(IES) to the MH TRANSMISSION SYSTEM or to otherwise accommodate an interconnection request and to address reliability concerns identified in the INTERCONNECTION EVALUATION STUDY. Good faith non-binding cost estimates for the required MH INTERCONNECTION FACILITY(IES) and the INTERCONNECTION SYSTEM UPGRADES; and a non-binding estimate of the time required to complete construction of the MH INTERCONNECTION FACILITY(IES) and the INTERCONNECTION SYSTEM UPGRADES will be provided. An INTERCONNECTION FACILITIES STUDY may also include:
- An electromagnetic transient study to determine equipment ratings,
 - Any studies required to satisfy the requirements of the systems of adjacent regional transmission committees (MAPP or its successor organization), regional transmission organizations (MISO or its successor organization), transmission owners, and local distribution systems.
- 1.1.17 INTERCONNECTION SYSTEM UPGRADES: The additions, modification and upgrades to the MH TRANSMISSION SYSTEM required to accommodate the interconnection of the FACILITY(IES) to the MH TRANSMISSION SYSTEM, as identified by the INTERCONNECTION STUDIES. Except for interconnecting the FACILITY(IES), these additions, modifications and upgrades would not be otherwise required; and include (i) upgrades necessary to remove thermal overloads and voltage criteria violations, and (ii) upgrades necessary to remedy short-circuit and/or stability problems. INTERCONNECTION SYSTEM UPGRADES shall not normally include upgrades to the MH TRANSMISSION SYSTEM that may be required to provide Transmission Service under the MH Open Access Transmission Tariff, and shall not include MH INTERCONNECTION FACILITY(IES). INTERCONNECTION SYSTEM UPGRADES may include upgrades to the MH TRANSMISSION SYSTEM if the GENERATOR is requesting

the NETWORK INTEGRATION TRANSMISSION SERVICE provided under the MH Open Access Transmission Tariff.

- 1.1.18 IOA: Interconnection Operating Agreement.
- 1.1.19 MAPP: Mid-Continent Area Power Pool.
- 1.1.20 MH: Manitoba Hydro-Electric Board.
- 1.1.21 MH HVdc TRANSMISSION SYSTEM: The MH \pm 463.5 kV Bipole I direct current transmission line extending from the Radisson Converter Station on the Nelson River in northern Manitoba to the Dorsey Converter Station located near Rosser in southern Manitoba, and the \pm 500 kV Bipole II direct current transmission line extending from the Henday Converter Station on the Nelson River in northern Manitoba to the Dorsey Converter Station located near Rosser in southern Manitoba, including the Radisson, Henday and Dorsey converter stations, and associated equipment.
- 1.1.22 MH INTERCONNECTION FACILITY(IES): All facilities and equipment owned and/or controlled, operated and maintained by MH, including any modifications, additions, or upgrades made to such facilities and equipment, that are necessary to physically and electrically interconnect the MH TRANSMISSION SYSTEM to the POINT(S) OF INTERCONNECTION. MH INTERCONNECTION FACILITY(IES) do not include INTERCONNECTION SYSTEM UPGRADES.
- 1.1.23 MH SYSTEM CONTROL CENTRE: Control Centre located in Winnipeg, Manitoba from which Manitoba Hydro controls its transmission system, including interconnections with other TRANSMISSION LINE OWNERS.
- 1.1.24 MH SYSTEM OPERATOR: Person authorized to operate or supervise operation of the MH TRANSMISSION SYSTEM.
- 1.1.25 MH TRANSMISSION SYSTEM: Transmission facilities, generally 60 kV and above, owned and operated by MH, and used to provide transmission service under Part II and Part III of the MH Open Access Transmission Tariff [5]; excluding the NORTHERN COLLECTOR SYSTEM and the MH HVdc TRANSMISSION SYSTEM.
- 1.1.26 MISO: Midwest Independent Transmission System Operator.
- 1.1.27 MRO: Midwest Reliability Organization.
- 1.1.28 NATIVE LOAD: The wholesale and retail power customers of MH on whose behalf MH, by statute, franchise, regulatory requirement, or contract, has undertaken an obligation to construct and operate MH's system to meet the reliable electric needs of such customers.
- 1.1.29 NERC: North American Electric Reliability Corporation.

- 1.1.30 NORTH AMERICAN GRID: Interconnected transmission network of transmission owners in the United States and Canada consisting of three interconnections: Eastern Interconnection, Western Interconnection and ERCOT Interconnection. The MH TRANSMISSION SYSTEM is interconnected with the transmission networks of other transmission owners within the Eastern Interconnection.
- 1.1.31 NORTHERN COLLECTOR SYSTEM: Isolated 138 kV and 230 kV transmission systems in Northern Manitoba owned by MH that interconnect the Nelson River Kettle, Long Spruce and Limestone GENERATOR FACILITY(IES)to the MH HVdc TRANSMISSION SYSTEM.
- 1.1.32 NETWORK CUSTOMER: An entity receiving transmission service pursuant to the terms of MH's NETWORK INTEGRATION TRANSMISSION SERVICE under Part III of the MH Open Access Transmission Tariff.
- 1.1.33 NETWORK INTEGRATION TRANSMISSION SERVICE: The transmission service provided under Part III of the MH Open Access Transmission Tariff.
- 1.1.34 NETWORK LOAD: The load that a NETWORK CUSTOMER designates for NETWORK INTEGRATION TRANSMISSION SERVICE under Part III of the MH Open Access Transmission Tariff. The NETWORK CUSTOMER'S NETWORK LOAD shall include all load served by the output of any NETWORK RESOURCES designated by the NETWORK CUSTOMER. A NETWORK CUSTOMER may elect to designate less than its total load as NETWORK LOAD but may not designate only part of the load at a discrete point of delivery. Where a NETWORK CUSTOMER has elected not to designate a particular load at discrete points of delivery as NETWORK LOAD, the NETWORK CUSTOMER is responsible for making separate arrangements under Part II of the MH Open Access Transmission Tariff for any Point-to-Point Transmission Service that may be necessary for such non-designated load.
- 1.1.35 NETWORK RESOURCE: Any designated generating resource or dedicated transmission equipment owned, purchased or leased by a NETWORK CUSTOMER, or by the load-serving entity where the NETWORK CUSTOMER is acting as an intermediary for the load-serving entity, and used to serve the load-serving entity's load on a firm basis, under the NETWORK INTEGRATION TRANSMISSION SERVICE provided under the MH Open Access Transmission Tariff. NETWORK RESOURCES do not include any resource, or any portion thereof, that is committed for sale to third parties (other than the load-serving entity on whose behalf the NETWORK CUSTOMER is acting) or otherwise cannot be called upon to meet the NETWORK CUSTOMER'S NETWORK LOAD on a non-interruptible basis.
- 1.1.36 OPERATING PROCEDURES: OPERATING PROCEDURES are a set of operating instructions carried out by the MH SYSTEM OPERATOR when certain events occur on the transmission system that may compromise security and reliability if no action is taken. OPERATING

PROCEDURES are developed as one of the following types: TEMPORARY OPERATING GUIDES, STANDING OPERATING GUIDES and EMERGENCY OPERATING GUIDES.

1.1.37 POINT(S) OF INTERCONNECTION: Point(s) on the INTERCONNECTION FACILITY(IES) where the CUSTOMER LOAD INTERCONNECTION FACILITY(IES) or GENERATOR INTERCONNECTION FACILITY(IES) or TRANSMISSION LINE OWNER INTERCONNECTION FACILITY(IES) interconnect with the MH INTERCONNECTION FACILITIES.

1.1.38 SPECIAL PROTECTION SYSTEM (SPS) OR REMEDIAL ACTION SCHEME (RAS): An automatic protection system or operating procedure designed to detect abnormal or predetermined system conditions, and take corrective actions other than and/or in addition to the isolation of faulted components to maintain system reliability. Such action may include changes in demand, generation (MW and Mvar), or system configuration to maintain system stability, acceptable voltage levels, or power flows. An SPS does not include (a) underfrequency or undervoltage load shedding or (b) protection equipment for the purpose of detecting and isolating fault conditions on equipment or (c) out-of-step relaying (not designed as an integral part of an SPS) or (d) a generally accepted transmission device that is planned and designed to provide dynamic control of electric system quantities (eg. HVdc links, high response exciters, static var compensators).

1.1.39 STANDING OPERATING GUIDES are developed for those FACILITY(IES) that are known problems under a variety of system conditions. These guides may be developed as seasonal guides and are effective for any time of the season. The STANDING OPERATING GUIDES specify the limitation on the FACILITY(IES) under normal and single critical element outage conditions. These guides also provide default operating limits for multiple critical outages, which usually triggers the request for TEMPORARY OPERATING GUIDES.

1.1.40 SUBSTANTIAL MODIFICATION: A modification to a GENERATOR FACILITY(IES) shall be considered substantial if it results in a change in:

- Real power output greater than 1.0 MW,
- Reactive power output greater than 1.0 Mvar,
- The protection system of the GENERATOR FACILITY(IES) or GENERATOR INTERCONNECTION FACILITY(IES),
- Dynamic response resulting from, but not limited to, a change to the excitation control system, automatic voltage regulator, governor control system, or generator damping capability.

A modification to a CUSTOMER LOAD FACILITY(IES) shall be considered substantial if it results in a change in:

- Demand that exceeds 1.0 MVA, (e.g. the addition of a motor load in excess of 200 hp),
- Demand that exceeds the maximum contractual demand,
- The reactive power facilities (e.g. reactors, capacitors, synchronous condensers),
- The protection system of the CUSTOMER LOAD FACILITY(IES) or CUSTOMER LOAD INTERCONNECTION FACILITY(IES),
- Load composition (e.g. the addition of a variable frequency drive),

- Load characteristics (e.g. modification to large motor starting logic).
- A modification to a TRANSMISSION LINE OWNER INTERCONNECTION FACILITY(IES) shall be considered substantial if it results in:
- The addition or deletion of terminating stations, including tapping of a transmission line,
 - Modification to the protection system(s),
 - The addition or retirement of reactive power facilities.

- 1.1.41 TEMPORARY OPERATING GUIDES are developed as a result of outage coordination and are required for a scheduled outage to be approved. The TEMPORARY OPERATING GUIDES specify the operating limits and mitigation actions and are effective only for the duration of the planned outage. TEMPORARY OPERATING GUIDES are also developed from EMERGENCY OPERATING GUIDES as a result of system EMERGENCY CONDITIONS that are anticipated to continue into the future.
- 1.1.42 TRANSMISSION LINE OWNER INTERCONNECTION FACILITY(IES): All facilities and equipment owned and/or controlled, operated and maintained in Manitoba by the TRANSMISSION LINE OWNER, including any modifications, additions, or upgrades made to such facilities and equipment, that are necessary to physically and electrically interconnect the TRANSMISSION LINE OWNER FACILITY(IES) to the POINT(S) OF INTERCONNECTION.
- 1.1.43 TRANSMISSION LINE OWNER: shall mean a NETWORK CUSTOMER or a transmission owner of an adjacent transmission system proposing to interconnect its TRANSMISSION LINE OWNER FACILITY(IES) to the MH TRANSMISSION SYSTEM or to make a SUBSTANTIAL MODIFICATION to its existing TRANSMISSION LINE OWNER INTERCONNECTION FACILITY(IES) connected to the MH TRANSMISSION SYSTEM.
- 1.1.44 TRANSMISSION LINE OWNER FACILITY(IES): A facility with electrical load and generation that may receive power from or interchange power with the MH TRANSMISSION SYSTEM. The TRANSMISSION LINE OWNER FACILITY(IES) may include its own generation, load, reactive power compensation, transformation, transmission and distribution.
- 1.1.45 WIND DATA shall mean the raw time and date stamped measurements averaged and recorded at a minimum of ten (10) minute intervals, as obtained from the meteorological tower data-loggers within the wind energy facility. The data includes accurate measurements of wind speed, wind direction, temperature and barometric pressure. The wind data shall include wind speed and wind direction measured at a minimum of two heights: (i) ten (10) meters, and (ii) as close to intended turbine hub elevation as practical and shall be measured using accepted calibrated wind industry monitoring equipment including meteorological tower data-loggers, which equipment shall be maintained and operated in accordance with good wind industry monitoring practice.

1.2 Scope and Revisions

This document defines technical requirements for FACILITY(IES) and establishes responsibilities of FACILITY OWNERS seeking to interconnect to the MH TRANSMISSION SYSTEM or with FACILITY(IES) already interconnected to the MH TRANSMISSION SYSTEM, subject to Section 1.4.

The requirements of this document are subject to revision at any time as may be required to ensure the reliability and security of the MH TRANSMISSION SYSTEM or to comply with changes to planning standards or criteria established by MH or outside bodies such as the MRO or its successor organization, and the NERC or its successor organization. The entity wishing to interconnect with the MH TRANSMISSION SYSTEM, or substantially modify its interconnected FACILITY(IES) or its portion of the INTERCONNECTION FACILITY(IES), must comply with the revision of this document in effect on the date when the Interconnection and Operating Agreement is executed between the FACILITY OWNER and MH.

1.3 Applicability

This document specifies the technical requirements for interconnecting GENERATOR FACILITY(IES) or CUSTOMER LOAD FACILITY(IES) or TRANSMISSION LINE OWNER FACILITY(IES) to the MH TRANSMISSION SYSTEM and is applicable:

- For interconnection of new FACILITY(IES);
- For a SUBSTANTIAL MODIFICATION to an existing FACILITY(IES) or GENERATOR, CUSTOMER LOAD or TRANSMISSION LINE OWNER INTERCONNECTION FACILITY(IES), interconnected to the MH TRANSMISSION SYSTEM. A SUBSTANTIAL MODIFICATION has the potential to impact the performance of the FACILITY(IES), the MH TRANSMISSION SYSTEM or adjacent transmission systems;
- Where the reliability of the MH TRANSMISSION SYSTEM is jeopardized due to unforeseen events associated with the FACILITY(IES) or GENERATOR, CUSTOMER LOAD or TRANSMISSION LINE OWNER INTERCONNECTION FACILITY(IES), MH reserves the right to enforce the requirements of this document;
- Where regulators, governments, or other external entities impose new obligations on MH, which require the FACILITY OWNERS to provide data, introduce new actions or processes, or add facilities in order to comply.

This document applies to:

- FACILITY(IES) interconnected to the MH TRANSMISSION SYSTEM at voltage levels generally at 60 kV and above,
- FACILITY(IES) interconnected at voltages above 25 kV and below 60 kV where the reliability of the MH TRANSMISSION SYSTEM may be impacted as determined from INTERCONNECTION STUDIES carried out by MH.

Additional technical requirements not covered in this document may apply for interconnecting new High Voltage direct current transmission or Flexible AC Transmission System (FACTS)

devices to the MH TRANSMISSION SYSTEM. Such additional technical requirements will be defined by MH on a case by case basis.

Additional technical requirements for interconnection to the Dorsey HVdc Converter Station, the Northern Collector System or future converter stations are not covered in this document and will be defined by MH on a case by case basis.

The FACILITY OWNER shall, where required, apply for Transmission Service from MH in accordance with the MH Open Access Transmission Tariff [5].

1.4 Objectives

This document lays out a common set of practices and design criteria that must be met by all FACILITY(IES) seeking to interconnect or are already interconnected to the MH TRANSMISSION SYSTEM, subject to Section 1.3. It is not the purpose of this document to define and summarize requirements for the design of equipment within the interconnecting FACILITY(IES). Rather, this document defines the interface between the MH TRANSMISSION SYSTEM and the FACILITY(IES) proposed for interconnection or existing FACILITY(IES) already interconnected to it.

Minimum technical requirements are defined with the objective of ensuring that the MH TRANSMISSION SYSTEM will operate reliably and safely under normal operating conditions, when the FACILITY(IES) are interconnected to it.

Some of the technical requirements cannot be precisely defined until the location and some basic information on the proposed new FACILITY(IES) is provided to MH. The final technical requirements will be determined by INTERCONNECTION STUDIES carried out by MH. The FACILITY OWNER will provide information, as described in Section 6.0, to MH for carrying out such studies.

1.5 Procedure for Interconnecting or Modifying Existing Facilities

The process for interconnecting new FACILITY(IES) to the MH TRANSMISSION SYSTEM or modifying FACILITY(IES) already interconnected to the MH TRANSMISSION SYSTEM is provided in the MH Open Access Interconnection Tariff (OAIT). Presently, the scope of the OAIT only covers GENERATOR FACILITY(IES). The procedure for new interconnections to neighbouring utilities is covered in the MH Open Access Transmission Tariff (OATT).

1.6 Inspection and Review

All information submitted by the FACILITY OWNER is subject to review by MH. MH reserves the right to require additional information and investigations as deemed necessary to ensure that the requirements outlined in this document are fulfilled. Where there is an existing agreement the process and procedures of that agreement will be followed.

New FACILITY(IES) or modified FACILITY(IES) are subject to inspection by MH prior to initial energization.

All interconnected FACILITY(IES) are subject to periodic review and inspection by MH to ensure that compliance with this document is being maintained. MH will provide reasonable notification as to the time and date of the inspection visit.

1.7 Failure to Comply

MH reserves the right to take whatever measures are necessary in its sole discretion to ensure that FACILITY(IES) and the FACILITY OWNER comply with the requirements of this document. Where the FACILITY(IES) and FACILITY OWNER fail to comply with the requirements of this document, the following consequences may occur:

1. The FACILITY OWNER is directed to perform remedial work to make the FACILITY(IES) compliant.
2. MH may disconnect, refuse to transmit or distribute power to or receive power from the FACILITY(IES) pursuant to Section 15(6) of *The Manitoba Hydro Act* or Section 17 of *Regulation 186/90 – Electric Power Terms and Conditions of Supply*.
3. The FACILITY OWNER may be liable for any damages occurring to the MH TRANSMISSION SYSTEM and/or any third party facilities.

2.0 MH TRANSMISSION SYSTEM - SYSTEM INFORMATION AND DESIGN PRACTICE

This section provides system information, operating limits and performance criteria applicable to the MH TRANSMISSION SYSTEM. It also provides information on some aspects of MH’s normal design practice related to equipment interconnected to or used on the MH TRANSMISSION SYSTEM.

The FACILITY OWNER’s equipment must be designed to operate within the operating limits defined in this document.

The information in this Section 2 is provided to assist the FACILITY OWNER in the planning and design of the FACILITY only and is subject to revision as noted in Section 1.2. The FACILITY OWNER must contact MH to obtain data for the specific POINT(S) OF INTERCONNECTION.

No.	Item	Information																										
2.1	Reliability Criteria	The MH TRANSMISSION SYSTEM is planned, designed and constructed to satisfy the requirements detailed in NERC TPL-001, TPL-002 and TPL-003., together with other requirements detailed in the NERC Reliability Standards [1] and the MRO Reliability Standards (or its successor organization) and Procedures [2].																										
2.2	Voltage Levels	Nominal voltage levels above 60 kV on the MH TRANSMISSION SYSTEM at which interconnection is possible are 66, 115, 138, 230 or 500 kV.																										
2.3	Voltage Variations	<p>The system nominal voltages, typical normal steady-state minimum and maximum operating voltage limits and voltages for rating of equipment are as follows:</p> <table border="1"> <thead> <tr> <th rowspan="2">System Nominal Voltage (kV)</th> <th colspan="2">Normal steady-state operating limits</th> <th rowspan="2">Voltage for rating of equipment (kV)</th> </tr> <tr> <th>Minimum Voltage (kV)</th> <th>Maximum Voltage (kV)</th> </tr> </thead> <tbody> <tr> <td>66</td> <td>63</td> <td>69</td> <td>72.6</td> </tr> <tr> <td>115</td> <td>109</td> <td>121</td> <td>127</td> </tr> <tr> <td>138</td> <td>131</td> <td>145</td> <td>152</td> </tr> <tr> <td>230</td> <td>219</td> <td>242</td> <td>253</td> </tr> <tr> <td>500</td> <td>475</td> <td>525</td> <td>550</td> </tr> </tbody> </table> <p>Equipment interconnected to the MH TRANSMISSION SYSTEM is capable of withstanding switching (or transient) and temporary (or dynamic) overvoltages and post-contingency voltages within $\pm 10\%$ of nominal system voltage.</p> <p>The MH Transmission Planning Criteria Dynamic Voltage Variation Criteria is: maximum short-term ac voltage: 1.3 pu for 12 cycles; 1.1-1.3 pu for 120 cycles</p>	System Nominal Voltage (kV)	Normal steady-state operating limits		Voltage for rating of equipment (kV)	Minimum Voltage (kV)	Maximum Voltage (kV)	66	63	69	72.6	115	109	121	127	138	131	145	152	230	219	242	253	500	475	525	550
System Nominal Voltage (kV)	Normal steady-state operating limits			Voltage for rating of equipment (kV)																								
	Minimum Voltage (kV)	Maximum Voltage (kV)																										
66	63	69	72.6																									
115	109	121	127																									
138	131	145	152																									
230	219	242	253																									
500	475	525	550																									

No.	Item	Information							
		<p>Equipment interconnected to the MH TRANSMISSION SYSTEM is capable of remaining in operation during transient undervoltages such as may occur during system swings following major disturbances where the voltage may drop as low as 0.7 p.u. for 30 cycles and remain below 0.9 p.u. for 2 seconds. MH TRANSMISSION SYSTEM dynamic voltage variation criteria for the 230 kV system is illustrated in Figure 1 of Section 8. Transient undervoltage criteria for 115kV and less depends upon the interconnection site.</p>							
2.4	Frequency and Frequency Variations	<ul style="list-style-type: none"> • The nominal system frequency is 60 Hz. • The normal variation is within ± 0.02 Hz of 60 Hz, and the maximum variation is within ± 0.5 Hz of 60 Hz when the MH TRANSMISSION SYSTEM remains interconnected with the NORTH AMERICAN GRID. • The frequency may drop below 57.5 Hz or rise to 63.5 Hz for up to 10 seconds immediately following a major disturbance that results in MH TRANSMISSION SYSTEM separation from the NORTH AMERICAN GRID. Following the initial 10 seconds after separation, the frequency variations could be up to ± 0.1 Hz for 10 to 15 minutes. <p>During extreme events such as a large generation loss in Manitoba that may cause isolation from the NORTH AMERICAN GRID, the frequency may drop below 57.5 Hz with an initial frequency decay rate of 1 Hz/s to 10 Hz/s.</p>							
2.5	Power Quality	<p>The MH TRANSMISSION SYSTEM is designed and operated such that its power quality levels are within the limits specified in PQS2000 [4], <i>“Power Quality Specification For Interconnection to Manitoba Hydro’s Electrical System.”</i></p>							
2.6	System Protection and Control	2.6.1 Protection System Implementation	Protection systems on the MH TRANSMISSION SYSTEM are to be implemented so as to ensure fast, reliable clearing of system faults.						
		2.6.2 Typical Fault Clearing Times	<p>Typical clearing times for single line-to-ground and three phase faults are as follows:</p> <table border="0" style="margin-left: 40px;"> <tr> <td>66 kV</td> <td>8 – 120 cycles</td> </tr> <tr> <td>115/138 kV</td> <td>5 – 8 cycles</td> </tr> <tr> <td>230 kV</td> <td>5 – 6 cycles</td> </tr> <tr> <td>500 kV</td> <td>3 – 4 cycles</td> </tr> </table> <p>Delayed clearing due to breaker failure can be up to 15 cycles. Clearing by backup protection can be up to 30 cycles. MH must be contacted to obtain maximum clearing times and the conditions under which the maximum clearing times apply for a specific POINT(S) OF INTERCONNECTION.</p> <p>Actual clearing time plus one cycle margin shall be used in INTERCONNECTION STUDIES.</p>	66 kV	8 – 120 cycles	115/138 kV	5 – 8 cycles	230 kV	5 – 6 cycles
66 kV	8 – 120 cycles								
115/138 kV	5 – 8 cycles								
230 kV	5 – 6 cycles								
500 kV	3 – 4 cycles								

No.	Item	Information	
		2.6.3 System Damping	<p>Power system stabilizers or equivalent transmission control devices are designed to have a positive damping effect on local generator oscillations as well as inter-plant and inter-area oscillations. The power oscillation damping ratio is not to be less than 0.00816 for disturbances with faults or less than 0.016766 for line trips in the MRO region. For disturbances within Manitoba, a power oscillation damping ratio which exceeds 0.05 is acceptable, between 0.03 and 0.05 is marginal and below 0.03 requires mitigation measures.</p>
		2.6.4 Transmission Line Protection Systems	<p>Transmission line protections are generally configured to provide detection and isolation of faults over the length of the line, plus backup clearing of faults for all adjacent elements and lines and typically consist of:</p> <ul style="list-style-type: none"> • <i>230 kV and above systems</i> <ul style="list-style-type: none"> - Dual relay packages are utilized. At least one package includes fault location capability, and each package includes reasonable waveform and events recording (e.g. digital packages). Both systems include communications aided tripping, generally employing separate routes, so as to provide high speed clearing of faults over the full line length, even if one system is out-of-service or fails to operate. • <i>115 kV and 138 kV systems (short networked lines):</i> <ul style="list-style-type: none"> - Dual relay packages are normally utilized. Both packages include communications aided tripping so as to provide high speed clearing of faults over the line length even if one package is out of service or fails to operate. High speed tripping is utilized for short lines to ensure coordination with remote timed backup relays of adjacent lines. At least one package includes some fault location capability, and waveform and events recording (e.g. digital package). - Loss of one communication system must not result in backup clearing of other (non-faulted) system elements unless one of the two communication systems is out-of-service for scheduled maintenance. • <i>115 kV and 138 kV systems (radial and long networked lines):</i> <ul style="list-style-type: none"> - Dual digital transmission line relay packages are utilized in most cases - At least one package normally includes some fault location capability, and waveform and events recording (e.g. digital packages)

No.	Item	Information
		<ul style="list-style-type: none"> • 66 kV systems (radial lines) <ul style="list-style-type: none"> - Phase and ground overcurrent elements are used either in a single digital relay package or as single phase units. A single digital relay package is typically utilized in new locations and the package normally includes some fault location capability, and waveform and events recording. - Redundant protection is not required if backup protection is provided at the source transformer bank.
		<p>Different dual protection packages are chosen so as to avoid the possibility of simultaneous failures to both systems due to manufacturer's defects, component failures, misunderstanding or misapplication of settings or functions. Also, dual packages allow taking a package out of service for maintenance. This can often be achieved through use of different manufacturer's equipment or devices working on different principles.</p> <p>Where transfer tripping to remote transmission line ends is utilised for apparatus primary protection (transformer banks, reactors), redundant communications on independent routes are utilised.</p> <p>Auxiliary power to relay systems including their communications (which in some sites uses dual battery systems) is normally from low noise battery systems capable of ensuring full protection for up to an 8-12 hour period after loss of MH TRANSMISSION SYSTEM supply. Where redundant relay systems are used, separate fusing is used for each of the redundant systems, including on ac potential circuits, and dc auxiliary power and tripping circuits.</p> <p>MH is required to develop documentation of the protection system maintenance and testing program in compliance with the requirements of the NERC Standard PCR-005-1 [1].</p>
	2.6.5 Monitoring Facilities	<p>MH uses monitoring facilities to analyze protection operations, system faults and system disturbances on the MH TRANSMISSION SYSTEM. Equipment used may include a combination of digital relays and meters with internal recording of events and waveforms, sequential events recording, transient fault recording, fault locating or disturbance recording equipment.</p> <p>Information gathered typically includes trip initiations (from relays or other protective sensors), system current and voltage waveforms, and breaker status. Where protection systems involve multiple sites (e.g. line protections), monitoring includes time tagging in sufficient detail and resolution to determine initiating conditions and sequence of</p>

No.	Item	Information													
			operations. Where the system elements have the potential to affect bulk power system stability, longer term disturbance recording functions are used. All information is generally in a format such that data can be quickly and easily exchanged with other entities as required by the MRO or NERC.												
2.7	Underfrequency Load Shed (UFLS)	<p>The MH UFLS program was placed into service to help ensure integrity of the MH TRANSMISSION SYSTEM during extreme power system events resulting in the loss of a large amount of generation. The MH UFLS is organized in blocks of load to be shed at fixed frequency set points as determined by MH.</p> <p>The load shed blocks are set to trip at one of the following fixed frequency set points: 59.3 Hz, 59.0 Hz, 58.7 Hz, 58.5 Hz, 58.3 Hz, 58.0 Hz, 57.5 Hz.</p>													
2.8	Undervoltage Load Shed (UVLS)	There are no UVLS schemes at present on the MH TRANSMISSION SYSTEM. MH reserves the right to implement an UVLS program.													
2.9	System Grounding	The MH TRANSMISSION SYSTEM is operated as effectively (solidly) grounded at nominal voltage levels above 100 kV and ungrounded at 66 kV. Grounding transformers may be used in 66 kV substations to achieve impedance grounding.													
2.10	Insulation Levels	<p>Insulation Levels used on the MH TRANSMISSION SYSTEM are:</p> <table border="1" data-bbox="565 968 1459 1276"> <thead> <tr> <th data-bbox="565 968 862 1020">Nominal Voltage (kV)</th> <th data-bbox="862 968 1459 1020">BIL (kV)</th> </tr> </thead> <tbody> <tr> <td data-bbox="565 1020 862 1062">66</td> <td data-bbox="862 1020 1459 1062">350</td> </tr> <tr> <td data-bbox="565 1062 862 1104">115</td> <td data-bbox="862 1062 1459 1104">550</td> </tr> <tr> <td data-bbox="565 1104 862 1146">138</td> <td data-bbox="862 1104 1459 1146">550 – 650</td> </tr> <tr> <td data-bbox="565 1146 862 1199">230</td> <td data-bbox="862 1146 1459 1199">900 everywhere 1050 special cases</td> </tr> <tr> <td data-bbox="565 1199 862 1276">500</td> <td data-bbox="862 1199 1459 1276">1550 for transformers and 1800 for all other equipment</td> </tr> </tbody> </table> <p>Lightning (Surge) Protection against direct lightning strokes shall be provided for protecting outdoor equipment including transformers.</p> <p>Lightning protection shall be designed for a zero rate of failure (that is, all voltage stresses are at least three standard deviations less than the critical flashover voltage) taking into account the regional lightning stroke density (estimated from either the Canadian Lightning Detection Network (CLDN) data or the local keraunic map if CLDN data is not available) and tower footing resistances as applicable.</p>		Nominal Voltage (kV)	BIL (kV)	66	350	115	550	138	550 – 650	230	900 everywhere 1050 special cases	500	1550 for transformers and 1800 for all other equipment
Nominal Voltage (kV)	BIL (kV)														
66	350														
115	550														
138	550 – 650														
230	900 everywhere 1050 special cases														
500	1550 for transformers and 1800 for all other equipment														
2.11	Short Circuit Levels	Equipment is designed for operation at short circuit levels that take into account future development and expansion of the MH TRANSMISSION SYSTEM. The short circuit levels at any POINT(S) OF INTERCONNECTION depend on the voltage level and location and are available on request from MH.													

No.	Item	Information	
2.12	Communication Systems	<p>Communication Systems are generally designed to have the following characteristics:</p> <ul style="list-style-type: none"> • For each required communication function, dual, independent, communications systems are used to interface between FACILITY(IES) and the designated MH site(s), such that "no foreseeable single event or single component failure shall cause a major loss of communications functionality". The two communication systems avoid common intermediate sites. FACILITY(IES) are able to operate with either system out of service. MH prefers to avoid using leased circuits, however a leased circuit is occasionally used as one of the two individual communication systems. • Each individual communication system has a high functional dependability and low probability of being out of service for a long period of time. The probability of both communication systems being simultaneously out of service is extremely low. The requirement is for a functional unavailability not to exceed 10 seconds per year. • Communications systems that are required to transmit or receive protection signals are designed to operate through power system faults or outages. • Sufficient communications capacity is provided to meet all the MH TRANSMISSION SYSTEM needs. • Communications systems meet MH design practices and are adequate to ensure that the MH TRANSMISSION SYSTEM performance meets power system reliability requirements. The relevant MH design practices are available on request from MH. • Communication channels are of high quality, suitable for analog and digital traffic at the required speeds. • Communications delays are minimised to allow for fast power system protection operation (no more than 2 milliseconds traffic delay). • Standby power is required for all telecommunications. A minimum battery capacity of twelve hours is required for typical sites. For difficult to access sites, larger battery capacity is required. • All communication systems are maintainable without jeopardising the MH TRANSMISSION SYSTEM or unreasonably affecting its operation. 	
2.13	Automatic Generation Control	<p>Manitoba Hydro is a control area and uses Automatic Generation Control to maintain system frequency and scheduled interchange levels. Automatic Generation Control is operated and monitored according to NERC Standard BAL-005-0.</p>	
2.14	Transformer Winding Configurations	<p>Typical transformer winding arrangements include:</p>	
		500 kV-230 kV-46 kV	grd. wye-grd. wye-delta (auto transformer)
		230 kV-115 kV-13.8 kV	grd. wye-grd. wye-delta (auto transformer)

No.	Item	Information										
		<table border="1"> <tr> <td data-bbox="565 296 967 348">230 kV-66 kV</td> <td data-bbox="967 296 1458 348">grd. wye-delta</td> </tr> <tr> <td data-bbox="565 348 967 401">230 kV-25 kV</td> <td data-bbox="967 348 1458 401">grd. wye-grd. wye with buried delta</td> </tr> <tr> <td data-bbox="565 401 967 453">115 kV-66 kV</td> <td data-bbox="967 401 1458 453">grd. wye-delta</td> </tr> <tr> <td data-bbox="565 453 967 506">115 kV-25 kV</td> <td data-bbox="967 453 1458 506">grd. wye-grd. wye with buried delta</td> </tr> <tr> <td data-bbox="565 506 967 562">115 kV-13.8 kV or 230 kV-13.8 kV</td> <td data-bbox="967 506 1458 562">grd. wye-delta (generator transformer)</td> </tr> </table>	230 kV-66 kV	grd. wye-delta	230 kV-25 kV	grd. wye-grd. wye with buried delta	115 kV-66 kV	grd. wye-delta	115 kV-25 kV	grd. wye-grd. wye with buried delta	115 kV-13.8 kV or 230 kV-13.8 kV	grd. wye-delta (generator transformer)
230 kV-66 kV	grd. wye-delta											
230 kV-25 kV	grd. wye-grd. wye with buried delta											
115 kV-66 kV	grd. wye-delta											
115 kV-25 kV	grd. wye-grd. wye with buried delta											
115 kV-13.8 kV or 230 kV-13.8 kV	grd. wye-delta (generator transformer)											
2.15	Station Battery	<p>Station battery for stations with a system restoration plan must be able to withstand a 12 hour outage to the battery chargers and must:</p> <ul style="list-style-type: none"> • be able to serve all normal dc loads, • survive the largest credible station event at the beginning of the 12-hour period, • survive one open-close-open operation on each station device during the 12-hour period with some margin. <p>Stations without a restoration plan may have a 16 hour battery capability.</p>										
2.16	OPERATING STUDIES AND PROCEDURES	<p>OPERATING STUDIES identify prior outage conditions that may limit the operation of the FACILITY(IES). These studies may identify stability constraints, NERC flow gates, NERC Available Transmission Capability (ATC), NERC Total Transmission Capability (TTC) and NERC Transmission Reliability Margin (TRM). Operating guidelines and procedures may be required for critical prior outages.</p>										
2.17	Modelling Data	<p>MH uses models for the following purposes:</p> <ul style="list-style-type: none"> • To determine compliance with interconnection criteria and performance standards. • To perform on-going system security analysis in operating studies including on-line dynamic security assessment. <p>This includes but is not limited to the following analysis:</p> <ul style="list-style-type: none"> • Steady state or contingency analysis to identify loading and voltage issues. • Voltage stability analysis to identify voltage collapse. • Time domain simulation in a full network power system model, typically for simulation studies up to 10 seconds and not normally more than 20 seconds to identify performance under steady state and disturbance conditions including remote faults and faults at or close to the point of interconnection. • Linear system analysis (eigenvalue analysis) to identify angle damping. <p>Different models may be required for each type of analysis. The model is suitable for transient and other dynamic stability analysis and is compatible with one of the following programs,</p> <ul style="list-style-type: none"> • PSS/E (Siemens Power Technologies Inc.). • TSAT, SSAT, VSAT (Powertech Labs). 										

No.	Item	Information
2.18	Equipment Ratings	The MH TRANSMISSION SYSTEM is planned, designed and constructed to satisfy the ratings detailed in “ <i>Facility Ratings Methodology for Manitoba Hydro’s Bulk Electric System</i> ”[29].

3.0 GENERATOR INTERCONNECTION REQUIREMENTS

This section defines the requirements that are applicable for individual generators or generating plants applying to interconnect to the 66 kV, 115 kV, 138 kV, 230 kV and 500 kV nominal voltage levels on the MH TRANSMISSION SYSTEM or existing generating plants applying for SUBSTANTIAL MODIFICATION to their GENERATOR FACILITY(IES).

No.	Item	Requirement
3.1	Interconnection Location and Voltage Level	<p>The GENERATOR may apply to interconnect to the MH TRANSMISSION SYSTEM at the nominal voltage levels above 60 kV as defined in Section 2.2. It may also be possible to interconnect at voltages below 60 kV as determined by MH [13].</p> <p>The voltage level and POINT(S) OF INTERCONNECTION to the MH TRANSMISSION SYSTEM are to be determined by MH in consultation with the GENERATOR. MH shall be the final authority in determining the POINT(S) OF INTERCONNECTION.</p>
3.2	Sealing of Technical Reports, Drawings, Memos, etc.	All reports, memos, drawings, equipment specifications, and modelling data of technical nature (excluding manufacturing drawings) shall be stamped by a Professional Engineer certified to practice in the Province of Manitoba in accordance with <i>The Engineering and Geoscientific Professions Act of Manitoba</i> .
3.3	OPERATING PROCEDURES	The GENERATOR shall abide by all procedures which are identified in the IOA and any OPERATING PROCEDURES, which include one of the following types: TEMPORARY, EMERGENCY OR STANDING OPERATING GUIDES, imposed by the MH SYSTEM OPERATOR [23].
3.4	Reactive Power Requirements	<p>The GENERATOR FACILITY(IES) shall be designed to provide reactive power supply and absorption capability acceptable to MH as per performance criteria in [1]. The adequacy of such capability shall be demonstrated by the INTERCONNECTION STUDIES and/or the studies associated with a request for transmission service [5]. INTERCONNECTION STUDIES and/or studies associated with a request for transmission service may require power factor capability in excess of the minimum requirements specified below.</p> <p>All GENERATOR FACILITY(IES) larger than 10 MW interconnected to the MH TRANSMISSION SYSTEM shall be able to control the voltage level at the POINT(S) OF INTERCONNECTION as determined by the MH SYSTEM OPERATOR by adjusting the generator's power factor.</p> <p>For GENERATOR FACILITY(IES) larger than 10 MW, the GENERATOR shall design the GENERATOR FACILITY(IES) to maintain power delivery at continuous rated power output measured at the generator terminals at a power factor within the range of 0.90 overexcited (leading) to 0.95 underexcited (lagging) [28],[29]. INTERCONNECTION STUDIES will determine if a range different from this may be permitted.</p> <p>For GENERATOR FACILITY(IES) smaller than 10 MW, the GENERATOR shall design the GENERATOR FACILITY(IES), at minimum, to maintain power delivery at continuous rated power output measured at the POINT(S) OF INTERCONNECTION at unity power factor.</p>

No.	Item	Requirement						
		<p>The reactive supply shall be available over the full range of operating conditions.</p> <p>The GENERATOR shall be responsible for providing any necessary reactive power facilities as determined by INTERCONNECTION STUDIES and/or studies associated with a request for transmission service.</p>						
3.5	Dynamic Power Requirements	<p>INTERCONNECTION STUDIES will determine the need for additional dynamic reactive power support to ensure post disturbance voltages remain within the "blue region" shown in Fig. 1 (Section 8). The dynamic reactive support may be required at the Point of Interconnection or at other points in the MH TRANSMISSION SYSTEM.</p>						
3.6	Voltage Variations	<p>The GENERATOR FACILITY(IES) and GENERATOR INTERCONNECTION FACILITY(IES), when interconnected to the MH TRANSMISSION SYSTEM at the applicable system nominal voltage, shall:</p> <ul style="list-style-type: none"> • Be capable of operating continuously within the minimum and maximum voltage limits as defined in Section 2.3 as applicable based on POINT(S) OF INTERCONNECTION. MH reserves the right to require the GENERATOR's equipment to be capable of operation outside the normal minimum and maximum values defined in Section 2.3 at specific locations on the MH TRANSMISSION SYSTEM. • Have equipment rated at the voltage levels for rating of equipment as defined in Section 2.3 as applicable at the POINT(S) OF INTERCONNECTION. • Be capable of remaining in operation during transient undervoltage events following system disturbances to the undervoltage levels and durations defined in Section 2.3. • Be capable of withstanding, switching (or transient) and temporary (or dynamic) overvoltages and remaining in service up to the voltage levels and durations defined in the Section 2.3. • Be capable of remaining in operation during undervoltages caused by nearby faults not on the INTERCONNECTION FACILITIES. The minimum voltage at the POINT(S) OF INTERCONNECTION on the 230 kV system is 0% for 7 cycles and less than 50% for 16 cycles. <p>Generator tripping will be permitted if required to prevent generator unit damage for voltage conditions outside the voltage limits defined above ("white region" in Figure 1).</p>						
3.7	Frequency Variations	<p>The design criteria for frequency variation used on the MH TRANSMISSION SYSTEM is given in Section 2.4. The GENERATOR FACILITY(IES) and GENERATOR INTERCONNECTION FACILITY(IES) are required to be designed to operate reliably for the following fundamental frequency range when interconnected to the MH TRANSMISSION SYSTEM:</p> <table border="1" data-bbox="498 1703 1432 1850"> <thead> <tr> <th data-bbox="498 1703 1016 1780">Under frequency Limit</th> <th data-bbox="1021 1703 1281 1780">Over frequency Limit</th> <th data-bbox="1286 1703 1432 1780">Minimum Time</th> </tr> </thead> <tbody> <tr> <td data-bbox="498 1787 1016 1850">60.0-59.0 Hz</td> <td data-bbox="1021 1787 1281 1850">60.0-61.5 Hz</td> <td data-bbox="1286 1787 1432 1850">N/A continuous</td> </tr> </tbody> </table>	Under frequency Limit	Over frequency Limit	Minimum Time	60.0-59.0 Hz	60.0-61.5 Hz	N/A continuous
Under frequency Limit	Over frequency Limit	Minimum Time						
60.0-59.0 Hz	60.0-61.5 Hz	N/A continuous						

No.	Item	Requirement		
		59.0-58.7 Hz	61.5-62.0Hz	10 minutes
		58.7-57.5 Hz	62.0-63.5 Hz	30 seconds
		<p>These ranges are set to coordinate with the MH UFLS program defined in Section 2.7.</p> <p>Generator tripping is permitted if required to prevent generator damage for frequency conditions outside the operating limits defined above.</p> <p>A GENERATOR FACILITY(IES) that does not meet the above underfrequency requirements shall arrange to automatically trip load (in addition to automatic/manual load already shed by the MH UFLS program) to match the anticipated generation loss, at comparable frequency levels. The GENERATOR shall coordinate frequency relay settings with MH.</p> <p>INTERCONNECTION STUDIES will determine if modifications to the over frequency limits are permitted or required based on the POINT(S) OF INTERCONNECTION.</p> <p>Refer to Figure 4 in Section 8 for the frequency tolerance curve for generator units.</p>		
3.8	Inertia Constant (H)	<p>The impact on stability performance of the inertia of the generator unit will be reviewed during the INTERCONNECTION STUDIES. The INTERCONNECTION STUDIES shall demonstrate the ability of the generator unit to maintain synchronism for typical fault clearing times (see Section 2.6.2) at or near the POINT(S) OF INTERCONNECTION.</p> <p>Mitigating measures to correct any performance issues will be determined during the INTERCONNECTION STUDIES. The GENERATOR shall be responsible for the cost of any mitigation.</p>		
3.9	Synchronous Generator Controls	3.9.1 Speed Governor	<p>Synchronous generator units shall have a functioning speed governor to ensure satisfactory frequency response. The speed governor shall have the following characteristics:</p> <ul style="list-style-type: none"> • 5% droop [1] , • Fully responsive to frequency deviations exceeding ± 0.036 Hz [1], • Capable of providing immediate and sustained response to abnormal frequency excursions, • Control generator speed stably during interconnected and also during islanded operation, • Control generator speed following full load rejection so as to prevent a trip on overspeed. <p>The performance requirements of the governor system shall be in accordance with IEEE Standard 125 [16] for hydraulic turbines and with IEEE Standard 122 [15] for steam turbines. Similar performance requirements shall apply to all types of prime movers.</p> <p>The GENERATOR shall be responsible for demonstrating stable performance with adequate damping under all operating conditions [6].</p>	

No.	Item	Requirement
	3.9.2 Excitation System	<p>New synchronous generator units and/or SUBSTANTIAL MODIFICATIONS to an existing GENERATOR FACILITY(IES) may require the addition of a high initial response type of exciter if INTERCONNECTION STUDIES demonstrate all or part of the following:</p> <ul style="list-style-type: none"> • The high initial response excitation system is required to meet minimum transient voltage criteria; • The high initial response excitation system is required to enhance the ability of the Generation Facility to damp electromechanical modes of oscillation and meet minimum damping criteria. • The generator unit size exceeds 70 MVA. <p>The excitation system shall be designed in accordance with the guidelines of IEEE Standard 421.4 [18].</p> <p>A static excitation system voltage response time will depend on results from INTERCONNECTION STUDIES, but shall not be greater than 100 milliseconds.</p> <p>For rotating exciters, the excitation system nominal response (historically referred to as the excitation system response ratio), at rated speed, shall be at least 2.0.</p> <p>The INTERCONNECTION STUDIES shall determine the required positive and negative ceiling voltage of the excitation system. The exciter ceiling voltage shall not be less than 2.0 times rated field voltage.</p> <p>The excitation system voltage response time, ceiling voltage and nominal response are defined in IEEE 421.1 [17].</p> <p>INTERCONNECTION STUDIES shall determine the need for excitation system limiters. Limiters shall be coordinated with generator protection so that limiter action will occur rather than protection action for system events resulting in voltage and frequency excursions within the ranges specified in Sections 2.3 and 2.4.</p>

No.	Item	Requirement	
		3.9.3 Automatic Voltage Regulator (AVR)	<p>A continuously acting AVR equipped with a line drop compensator, or equivalent, providing a minimum of 60% line drop compensation shall be required for each GENERATOR FACILITY(IES) rated larger than 10 MW. The AVR shall have the capability to maintain the steady-state voltage within $\pm 0.5\%$ of the set point at the POINT(S) OF INTERCONNECTION or other control point as determined by the MH SYSTEM OPERATOR. AVR/exciter operation shall be stable and transient gain reduction shall not be used to preserve control system stability.</p> <p>A GENERATOR FACILITY(IES) interconnected to the MH TRANSMISSION SYSTEM that is not equipped with an AVR, may be required to install an AVR if SUBSTANTIAL MODIFICATIONS, as defined in 1.1.40, are undertaken. MH will determine the need for an AVR based on the results of the INTERCONNECTION STUDIES.</p> <p>The MH SYSTEM OPERATOR will determine the AVR voltage control set point.</p>
		3.9.4 Joint Var Control	<p>For an interconnection of a generating plant consisting of several units, joint var control capability shall be provided with the capability to control a remote bus. The joint var control requirements are to be determined in consultation with MH.</p>
		3.9.5 Power Ramp Rates	<p>The real power output of the GENERATOR FACILITY(IES) is required to be adjustable. MH will review if the power ramp rate is adequate to follow load if MH requires the generators to be on Automatic Generation Control (AGC) or any other load control scheme. Typical power ramp rates are 2 MW/second.</p>
		3.9.6 Maximum Power Limit	<p>The maximum output of the GENERATOR FACILITY(IES) shall be specified in the IOA. When in operation, the GENERATOR FACILITY(IES) shall not exceed this maximum output value.</p>

No.	Item	Requirement	
		3.9.7 Power System Stabilizer (PSS)	<p>All generator units 70 MVA or larger shall be provided with a PSS and a high initial response static exciter. INTERCONNECTION STUDIES will determine the required voltage response time. The voltage response time shall not exceed 100 ms.</p> <p>If INTERCONNECTION STUDIES determine that the PSS does not provide significant damping to electromechanical modes of oscillation then the static excitation system shall have the capability of accepting a stabilizing signal input as a minimum requirement.</p> <p>Synchronous generator units with a lower rating than 70 MVA may also need a PSS to enhance damping. The need to provide a PSS on smaller units and the required characteristics of the PSS will be determined by MH during INTERCONNECTION STUDIES.</p>
		3.9.8 Automatic Generation Control (AGC)	<p>MH reserves the right to require that generator units be capable of AGC operation. MH will determine the need for AGC operation during the INTERCONNECTION STUDIES. Typical AGC requirements are provided in Section 2.13 and shall meet NERC Standard BAL-005-0. The MH SYSTEM OPERATOR shall determine AGC operating protocol and operating set points.</p>
3.10	Synchronizing Facilities	<p>The GENERATOR shall provide synchronizing facilities including a facility for backup manual synchronizing.</p> <p>Synchronizing shall normally be accomplished through the closing of a circuit breaker under the control of an automatic synchronizer with automatic voltage and speed matching for the incoming generator so as to achieve a “bumpless” connection with minimum disturbance to the MH TRANSMISSION SYSTEM.</p> <p>The GENERATOR shall be responsible for determining the synchronizer settings. The GENERATOR shall resolve any adverse effects caused by generator synchronization. Typical maximum synchronizer settings are:</p> <ul style="list-style-type: none"> • Frequency difference: 0.10 Hz, • Voltage difference: 3%, • Phase angle difference: 20 degrees. <p>The GENERATOR FACILITY(IES) operator is responsible for synchronization of the GENERATOR FACILITY(IES) to the MH TRANSMISSION SYSTEM subject to authorization from the MH SYSTEM OPERATOR.</p>	
3.11	SPECIAL PROTECTION SYSTEMS (SPS) OR REMEDIAL ACTION SCHEMES (RAS)	<p>The generator units shall be designed with capability of being either direct tripped or automatically run back to reduce power output. INTERCONNECTION STUDIES may require implementation of other SPS or RAS schemes. Such requirements may be imposed at any time as dictated by the requirements of the MH TRANSMISSION SYSTEM. Design of SPS or RAS schemes will be subject to the requirements defined in NERC Standards PRC-012-0 to PRC-017-0 [1].</p>	

No.	Item	Requirement	
3.12	BLACK START CAPABILITY	<p>MH may require the GENERATOR to provide BLACK START CAPABILITY of the GENERATOR FACILITY(IES) if deemed necessary based on the location of the POINT(S) OF INTERCONNECTION and type of generator. INTERCONNECTION STUDIES will determine specific black start requirements which shall include but are not limited to:</p> <ul style="list-style-type: none"> • The capability of the BLACK START FACILITY to close onto a dead bus within 30 minutes from receipt of a start signal. • The ability of the BLACK START FACILITY to follow load pickup and regulate frequency. • To ensure that the BLACK START FACILITY has sufficient reactive reserve capacity to energize transmission, pick up load and further build the island. • A fuel supply in sufficient quantity to operate at accredited capacity for a minimum of 20 hours and/or at 50% of accredited capacity for 40 hours. <p>If BLACK START CAPABILITY is required and the GENERATOR FACILITY(IES) is not manned, the GENERATOR shall provide, at MH expense, the necessary telemetering and communication facilities to remotely control the following quantities from the MH SYSTEM CONTROL CENTRE:</p> <ul style="list-style-type: none"> • Start the black start unit (standby diesel, house unit, battery etc.), • Black start the GENERATOR FACILITY, • Disable the generation automatic load feature, • Adjust the governor droop settings, • Control of generator unit governor to raise/lower frequency set point. • Control of generator unit Automatic Voltage Regulation set point. <p>The MH SYSTEM OPERATOR shall specify the required tests to certify BLACK START CAPABILITY [23]. These include but are not limited to:</p> <ul style="list-style-type: none"> • Verification of communications. • Start-up of supplemental generator. • Start-up of the Black Start Unit. • Line energizing tests. • Load carrying tests. 	
3.13	Power Quality	3.13.1 Power Quality	The GENERATOR FACILITY(IES) and GENERATOR INTERCONNECTION FACILITY(IES) shall be designed and operated such that its power quality levels are within the limits specified in PQS2000, “Power Quality Specification For Interconnection to Manitoba Hydro’s Electrical System” [4].

No.	Item	Requirement	
		3.13.2 Resonance and Self-Excitation	<p>The GENERATOR FACILITY(IES) and GENERATOR INTERCONNECTION FACILITY(IES) shall be designed to avoid introducing detrimental resonances into the MH TRANSMISSION SYSTEM.</p> <p>The GENERATOR shall assess the risk of self-excitation of machines and implement appropriate design measures to protect the GENERATOR FACILITY(IES) as required. The GENERATOR shall work in consultation with MH to determine an appropriate solution.</p> <p>MH will provide the GENERATOR with harmonic impedance characteristics at the POINT(S) OF INTERCONNECTION on request. The GENERATOR shall ensure that any issues related to resonance and self-excitation are addressed in the GENERATOR FACILITY(IES) design.</p>
3.14	Protection Requirements	<p>Information on the MH TRANSMISSION SYSTEM protection and control practices is provided in Section 2.6.</p> <p>The GENERATOR shall be responsible for the following:</p> <ul style="list-style-type: none"> • To ensure that the GENERATOR FACILITY(IES) and GENERATOR INTERCONNECTION FACILITY(IES) are protected for all operating conditions and for all faults on the MH TRANSMISSION SYSTEM. • To install protective relaying equipment and systems that will sense and properly react to failure and malfunction of the GENERATOR FACILITY(IES) and GENERATOR INTERCONNECTION FACILITIES. The design of protective relaying installations will be in accordance with accepted industry standards [7] and shall satisfy criteria in NERC Standards VAR-001-1, VAR-002-1, PRC-003-1, PRC-004-1, PRC-005-1, PRC-019-1, and MOD-027-1 [1]. The protection shall fully protect the safety of the public and of MH personnel interfacing with the GENERATOR FACILITY(IES) and GENERATOR INTERCONNECTION FACILITIES. • To install high side breaker fail protection or fault interrupting devices located at or near the POINT(S) OF INTERCONNECTION. 	

No.	Item	Requirement
		<ul style="list-style-type: none"> • To provide MH with information as to the type of protection used and the settings for these protections. MH shall be the final authority on establishing control and protection settings that impact the operation of the MH TRANSMISSION SYSTEM. • Determining the settings for relays that protect the generator units and other plant equipment. The GENERATOR shall coordinate the protection and associated protection settings for installed equipment in the GENERATOR FACILITY(IES) and GENERATOR INTERCONNECTION FACILITY(IES) with the settings of the MH TRANSMISSION SYSTEM protection schemes in the area. MH will provide details of the MH system protection to the GENERATOR to facilitate this coordination. • The GENERATOR shall produce a protection relay coordination report that clearly demonstrates protection coordination. This report shall be submitted to MH for review and approval prior to the first energization of the GENERATOR FACILITY(IES). <p>Fault interrupting devices shall have adequate fault interrupting and momentary withstand ratings to satisfy the short circuit level requirements (see Section 3.20) and shall meet maximum clearing times established by the INTERCONNECTION STUDIES. Typical clearing times are given in Section 2.6.2.</p> <p>In cases where INTERCONNECTION STUDIES indicate the reliability of the MH TRANSMISSION SYSTEM may be jeopardized, MH may require the GENERATOR to install additional protection. MH will provide information as to the type of additional protections and the required clearing times of these protections. These protections can include but are not limited to the following:</p> <ul style="list-style-type: none"> • Bus differential, • Overvoltage, • Undervoltage, • Breaker failure, • Out of step, • Reverse power, • Islanding, • Voltage balance, • Directional overcurrent, and • Transfer trip. <p>Data on these protection and control systems including settings, as requested in Section 6.1, shall be provided to MH.</p>

No.	Item	Requirement	
3.15	Communications	<p>Communications facilities are required between the GENERATOR FACILITY(IES) and the MH TRANSMISSION SYSTEM. The GENERATOR shall provide and maintain the required communications from the GENERATOR FACILITY(IES) to the site(s) designated by MH. The communications type and performance shall be adequate for its intended use and shall satisfy the requirements further specified herein. MH will specify the interface at its sites.</p> <p>Communications may be required but are not limited to:</p> <ul style="list-style-type: none"> • System protection, • SPECIAL PROTECTION SYSTEMS (SPS) or REMEDIAL ACTION SCHEMES (RAS), • Supervisory control (including associated data acquisition and alarms), • Telemetry, • Operational voice communication, from a stand alone dedicated voice line that is capable of functioning for up to 12 hours in a system or site shutdown condition or complete loss of station service supply, • Facsimile and e-mail communication. <p>The exact requirement for communications, and functional characteristics, will be dependent on the function served and where appropriate by the reliability and/or redundancy defined during INTERCONNECTION STUDIES.</p> <p>Information on MH practice with regard to communications is available in Section 2.6.4 and 2.12.</p> <p>All communications maintenance and planned outages shall be coordinated through MH.</p>	
3.16	Revenue Metering	3.16.1 General	<p>All measuring devices and metering equipment required for revenue metering shall be owned, supplied, installed and maintained by MH at the GENERATOR'S expense. Metering shall conform to the Transmission Owners Customer Metering Standards [20].</p> <p>The specific types of metering equipment, timing devices, locations of meters, the details of the metering arrangement and the records to be kept shall be compatible with normal MH practice and shall be determined by MH in consultation with the GENERATOR.</p> <p>If the GENERATOR is a seller of electricity, they are required by Measurement Canada to hold a Certificate of Registration and be in conformance with the <i>Electricity and Gas Inspection Act and Regulations</i>.</p>

No.	Item	Requirement
		<p>3.16.2 Accuracy Revenue quality metering equipment shall consist of meters approved for revenue metering by Industry Canada. Metering equipment shall be installed, calibrated, repaired, replaced, maintained and tested in accordance with the provisions of <i>The Electricity and Gas Inspection Act</i>[21], <i>Electricity and Gas Inspection Regulations</i>, Measurement Canada and Manitoba Hydro specifications [24].</p> <p>MH requires 3 element metering accuracy for wye circuits and 2 element metering accuracy for delta circuits.</p> <p>Potential and current transformers for revenue metering shall conform to the Standard CAN3-C13-M83 for 0.3 metering accuracy class. Independent current transformers are required. Additional secondary windings on voltage transformers may be used for other purposes such as protective relaying as long as the burden is not excessive.</p>
		<p>3.16.3 Metering Configuration</p> <p>The following signals are to be provided:</p> <ul style="list-style-type: none"> • Active and reactive power, • Hourly integrated real and reactive power, where required. • Demand power, where required. <p>Instrument Transformers and such other devices or equipment as shall be necessary to give the instantaneous values of megawatts and megavars, and an automatic record of kilowatt-hours and megavar-hours for each clock hour. Metering shall be able to provide monthly accumulated active and reactive power quantities.</p> <p>When there is a possibility of flows of electricity in either direction, dual register metering equipment shall be installed to record metering data for each direction of flow.</p> <p>Two revenue meters shall be installed if MH supplies the station load directly.</p>
		<p>3.16.4 Energy Losses</p> <p>Metering shall be installed at the POINT(S) OF INTERCONNECTION. Where metering is installed at a different location, the metering shall be compensated for losses to the POINT(S) OF INTERCONNECTION.</p> <p>A disconnect device shall not be installed between the power transformer and the point of metering to ensure that no-load losses are correctly registered.</p>
		<p>3.16.5 Meter Reading</p> <p>Revenue meters may be read locally once per month by MH or may be remotely accessed by MH via telephone. Telemetry facilities to transmit monthly and hourly real and reactive power revenue metering data to MH's SYSTEM CONTROL CENTRE or other facility as directed by MH, shall be provided by the GENERATOR. Telemetered data shall be in a format compatible with MV90 data collection software or other format as specified by MH.</p>

No.	Item	Requirement	
		3.16.6 Check Metering	The GENERATOR shall provide backup metering or check metering if required. Check metering shall not be connected to the instrument transformers used for revenue metering in the GENERATOR FACILITY(IES).
		3.16.7 Meter Seals	Meters shall be sealed and the seals may be broken only by an inspector or accredited meter verifier appointed under the <i>Electricity and Gas Inspection Act</i> , R.S.C. 1985, c.E-4 [21] and then only for the purposes of inspection, verification, testing, re-verification or adjustment in accordance with provisions of the <i>Electricity and Gas Inspection Act</i> .
		3.16.8 Meter Tests	Periodically the MH shall specify tests [23] to confirm the accuracy of meters including but not limited to: <ul style="list-style-type: none"> • Instrument transformers. • Meters/data Loggers. • Alarms and Monitoring Facilities. • Communications Test. • General Quality • Site Documentation. • Error Correction Factors • Loss Adjustments.
		3.16.9 Security Audit	The MH shall have the right, upon 48 hours written notice, to audit the site security of the metering installation [23]. This shall include, but not be limited to, <ul style="list-style-type: none"> • Instrument transformers. • Meters/data Loggers.
3.17	Telemetry, Metering, and Supervisory Control and Data Acquisition(SCADA)	The GENERATOR shall provide a Remote Terminal Unit (RTU) or Data Link to a MH RTU capable of exchanging SCADA information with the MH SYSTEM CONTROL CENTRE. The protocol for data exchange via the RTU shall be compatible with that used for communications by the MH SYSTEM CONTROL CENTRE. MH will provide the GENERATOR with the protocol for data exchange.	

No.	Item	Requirement
		<p>As a minimum, the GENERATOR is required to provide the following data needed by the Supervisory Control and Data Acquisition (SCADA) system:</p> <ul style="list-style-type: none"> • Hourly integrated billing MWh (see 3.16), • Hourly integrated MVARh (see 3.16), • Individual generator(s) MW and MVAR, where identified, • Generator(s) breaker status, • Individual generator on/off status, if no generator breaker exists, • Total station instantaneous MW and MVAR, • Station service instantaneous MW, MVAR, hourly MWh and MVARh, • Generator transformer(s) high voltage side breaker(s) and isolator(s) status, • Bus voltage at high voltage bus, • Forebay elevation, if applicable, • Tailrace elevation, if applicable, • Unit discharge hourly, if applicable, • Total plant discharge hourly, if applicable, • Instantaneous wind velocity kph at turbine elevation, if applicable, • PSS status, if applicable, • AVR status, if applicable, • AVR voltage setpoint, if requested, • Total plant MW setpoint, if requested, • Instantaneous ambient temperature, if requested, • Generator step-up transformer tap setting, if requested. <p>SCADA readings shall be taken in four (4) second intervals.</p>

No.	Item	Requirement
		<p>If an AVR is required, the GENERATOR shall either provide full supervisory control facilities for each generator unit or a total plant Mvar control point adjustable from the MH SYSTEM CONTROL CENTRE, or provide 24 hour telephone access to a continuously staffed or remotely controlled GENERATOR FACILITY(IES) control centre via a dedicated phone line. Within an agreed time (typically 10 minutes), the GENERATOR FACILITY(IES) shall be able to adjust the voltage set point as directed by the MH SYSTEM OPERATOR.</p> <p>All measuring devices and metering equipment required for this purpose shall be supplied, installed and maintained by the GENERATOR.</p> <p>If the GENERATOR FACILITY(IES) is dispatched by the MH SYSTEM OPERATOR, the GENERATOR shall either provide full supervisory control facilities for each generator unit or a total plant MW control point adjustable from the MH SYSTEM CONTROL CENTRE, or provide 24 hour telephone access to a continuously staffed or remotely controlled GENERATOR FACILITY control centre via a dedicated phone line. Within an agreed time, the GENERATOR FACILITY(IES) shall be able to:</p> <ul style="list-style-type: none"> • Start-up, synchronize and fully load the available generators and, • Change the output of any of the on-line generators within the limits of the generator design and subject to Section 3.9.5. <p>The GENERATOR FACILITY(IES) may need to be connected to the MH Automatic Generation Control system as determined by MH. If MH requires the generator unit to be connected to the AGC system, the GENERATOR shall provide the appropriate telemetering equipment for the AGC signals.</p> <p>GENERATOR FACILITY(IES) larger than 2 MW may be required to be dispatchable as determined by MH. There could be exception for smaller GENERATOR FACILITY(IES) depending on the POINT(S) OF INTERCONNECTION. Refer to telemetering block diagram in Section 8, for an overview of the communication requirements for non-dispatchable (Figure 2) and for dispatchable generation (Figure 3).</p>
3.18	Disturbance Monitoring	<p>If directed by MH, the GENERATOR shall provide facilities for disturbance monitoring in accordance with MH specifications. MH will determine the need for disturbance monitoring during INTERCONNECTION STUDIES.</p> <p>Dynamic Swing Recording data and/or transient fault recording data shall be provided to MH on request to allow post fault analysis of any disturbances that adversely impact the MH TRANSMISSION SYSTEM in order to determine the possible fault cause and remedial action necessary.</p> <p>Information on monitoring facilities typically used by MH is available in Section 2.6.5.</p>

No.	Item	Requirement
3.19	Insulation Levels	<p>The GENERATOR FACILITY(IES) and GENERATOR INTERCONNECTION FACILITY(IES) shall comply with CAN/CSA C22.3 C71 “Insulation Coordination (Part 1: Definitions, Principles and Rules, Part 2: Application Guide)”.</p> <p>Equipment interconnected to the MH TRANSMISSION SYSTEM on the high voltage side of generator transformer(s) shall be insulated to at least the basic insulation levels (BIL) applicable to the system nominal voltage defined in Section 2.10, subject to insulation coordination studies. The GENERATOR shall be responsible for conducting insulation coordination studies.</p>
3.20	Short Circuit Levels	<p>The GENERATOR FACILITY(IES) and GENERATOR INTERCONNECTION FACILITY(IES) shall be designed for operation at short circuit (fault) levels that take into account future development of the MH TRANSMISSION SYSTEM. The short circuit levels to be used in the design depend on the POINT(S) OF INTERCONNECTION and future planned development and are available on request from MH. If the GENERATOR FACILITY(IES) causes fault current limits of existing equipment interconnected to the MH TRANSMISSION SYSTEM to be exceeded, the GENERATOR is responsible for mitigation. Impacted equipment will be identified and mitigation costs determined in INTERCONNECTION STUDIES.</p>
3.21	Grounding	<p>Each generating unit forming part of the GENERATOR FACILITY(IES) shall be grounded in accordance with electric industry practice [8].</p> <p>The overall grounding for the GENERATOR FACILITY(IES) shall be designed in accordance with the guidelines of IEEE Standard 80 [10]. The INTERCONNECTION STUDIES shall determine if modifications to the ground grids of existing substations are necessary to keep grid voltage rises within safe levels.</p>
3.22	Lightning (Surge) Protection	<p>Lightning (Surge) Protection against direct lightning strokes shall be provided for protecting outdoor equipment including transformers forming part of the GENERATOR FACILITY(IES) and the GENERATOR INTERCONNECTION FACILITY(IES).</p> <p>Lightning protection shall be designed for a zero rate of failure (that is, all voltage stresses are at least three standard deviations less than the critical flashover voltage) taking into account the regional lightning stroke density (estimated from either the the Canadian Lightning Detection Network (CLDN) data or from a local keraunic level map if the CLDN data is not available) and tower footing or grounding grid resistances as applicable to the GENERATOR FACILITY(IES) and GENERATOR INTERCONNECTION FACILITY(IES) .</p>
3.23	Safety	<p>The GENERATOR FACILITY(IES) and GENERATOR INTERCONNECTION FACILITY(IES) shall comply with safety requirements in the Canadian Electrical Code [19] and all applicable safety standards mandatory within the Province of Manitoba.</p>
3.24	Design Standards	<p>The GENERATOR FACILITY(IES) and GENERATOR INTERCONNECTION FACILITY(IES) shall be designed to comply with requirements of the Canadian Electrical Code [19] and any provincial codes applicable within the Province of Manitoba.</p>

No.	Item	Requirement
3.25	Environmental Conditions	Any equipment that can impact the MH TRANSMISSION SYSTEM shall be designed to function safely and reliably under the environmental conditions prevalent at the selected site. In particular, such equipment located outdoors at the POINT(S) OF INTERCONNECTION necessary for isolating the GENERATOR INTERCONNECTION FACILITY(IES) from the MH TRANSMISSION SYSTEM shall function reliably in extreme cold weather conditions with minimum temperatures as low as -50°C .
3.26	Clearances and Access	Energized parts shall be maintained at safe vertical and horizontal clearances that are compliant with the Canadian Electrical Code Part 3 [19].
3.27	Isolation	The GENERATOR shall provide fault interrupting devices and isolating devices at a location(s) defined by MH at or near the POINT(S) OF INTERCONNECTION.
		<p>Isolating devices shall be manually operable or motor operated isolation switches that provide visual electrical isolation. The isolation switch shall simultaneously operate all phases (i.e. gang-operated open/close). In some instances, MH may require motor operated isolation switches to allow rapid remote or automatic isolation from the MH TRANSMISSION SYSTEM. The requirement to provide motor operated isolation devices will be determined by MH on a case by case basis. Provision shall also be made for MH to padlock these isolation switches securely in the open position as per the MH Corporate Safety and Occupational Health Rules [12].</p> <p>If the POINT(S) OF INTERCONNECTION is remote from the interconnecting MH substation, then the isolating device(s) shall also have a safety ground switch(es) installed on the MH side of the isolating device(s). The need for the safety ground switch(es) will be determined during INTERCONNECTION STUDIES.</p>
3.28	Transformer Connection	<p>Transformer reactance and tap settings shall be coordinated with MH to optimize the leading and lagging reactive power capability that can be provided to the network. The transformer shall be designed in accordance with IEEE Standard C57.116 [14].</p> <p>The transformer connection is normally required to be delta on the generator side and grounded star on the MH TRANSMISSION SYSTEM side so as to block transmission of triplen harmonic currents and isolate generator and transmission side grounding networks. If this is not practical, an alternative arrangement acceptable to MH is to be determined in consultation with MH. Typical MH transformer configurations are provided in Section 2.14.</p> <p>Tap changers shall be supplied with adequate tap changer range to allow operation over the range of operating voltage, at the POINT(S) OF INTERCONNECTION, specified in Section 2.3.</p>

No.	Item	Requirement
3.29	Modelling Data and Special Tests	<p>The GENERATOR shall provide preliminary modelling data for the generator and associated equipment for INTERCONNECTION STUDIES and final as-built modelling data following commissioning of the GENERATOR FACILITY.</p> <p>The GENERATOR shall determine and document actual generator unit capability, reactive power limits, control settings and response times of generation equipment by field verification and testing to validate generator models and data provided to MH. The test procedures used to validate the response of the generator units shall follow the MRO Generator Testing Requirements [6].</p> <p>The GENERATOR shall provide detailed models for INTERCONNECTION STUDIES. If the models are proprietary, MH will sign a non-disclosure agreement.</p> <p>The GENERATOR shall provide non-proprietary models in standard IEEE format. These models may be released to external regional organizations such as the MRO, MISO, etc. for joint regional studies.</p> <p>All models shall be in a format which can be used by PSS/E and shall be maintained by the GENERATOR. The GENERATOR shall be responsible to re-validate all modelling data from time to time as requested by MH or as required by NERC MOD-010-0, MOD-011-0, MOD-012-0, and MOD-013-1.</p>
3.30	Testing and Maintenance Coordination	<p>The GENERATOR shall provide planned testing and maintenance work schedules for equipment within the GENERATOR FACILITY(IES). MH shall be given advance notification of planned outages for scheduled test and maintenance work.</p> <p>The GENERATOR shall have a generation protection system maintenance and testing program in place, NERC Standard PRC-005-1 [1]. Documentation of the protection system maintenance and testing program for the GENERATOR FACILITY(IES) shall be provided to MH.</p>
3.31	Inspection Requirements	<p>The GENERATOR FACILITY(IES) and GENERATOR INTERCONNECTION FACILITY(IES) shall be open to inspection by MH, whenever requested, for verification of compliance with this document. MH shall provide reasonable notice to the GENERATOR of the proposed date for any planned inspection visits.</p>
3.32	Coordinated Joint Studies	<p>THE GENERATOR shall cooperate with MH and participate in any coordinated joint studies or investigations required to verify or confirm compliance with NERC Reliability Standards or the requirements in this document. Procedures are defined in the MH Open Access Interconnection Tariff, Section 3.5 Coordination with Adjacent Systems.</p>
3.33	Notification of New or Modified Facilities	<p>The GENERATOR shall give reasonable notice to MH of any planned SUBSTANTIAL MODIFICATIONS or additions to existing facilities impacting the MH TRANSMISSION SYSTEM and obtain MH's approval for the modifications before proceeding with the work. Procedures are defined in the MH Open Access Interconnection Tariff, Section 3.5.</p>

No.	Item	Requirement
3.34	Special Interconnection Requirements	<p>The GENERATOR FACILITY(IES) shall meet the approval requirements of the current regional reliability organization.</p> <p>A GENERATOR FACILITY(IES) that plans to operate in long-term parallel operation with the MH TRANSMISSION SYSTEM, shall submit INTERCONNECTION STUDIES to be reviewed and approved by the MAPP Regional Transmission Committee (or its successor organization).</p>
3.35	Generation Forecasting	<p>The MH requires the output forecast of the FACILITY(IES) to enable the operation of the TRANSMISSION SYSTEM in accordance with Good Utility Practice [23]. Prior to energization and thereafter the GENERATOR shall provide the following data at a frequency determined by the MH SYSTEM OPERATOR:</p> <ul style="list-style-type: none"> • Availability of generation in MW for any prime mover fuel limitations. • Generation unit data including unit identification, date/time/ power and status. • A weekly generation plan seven days prior to the date of dispatch. • Site limitations that may reduce the accuracy of the forecast (e.g. ice, water license restrictions, temperature limits).

4.0 WIND GENERATOR INTERCONNECTION REQUIREMENTS

This section covers interconnection requirements specific to wind turbine generators. The interconnection requirements from Section 3 still apply unless otherwise indicated in this section. The minimum requirements specified here do not make any distinction as to types of wind generation turbine technology.

No.	Item	Requirement
4.1	Voltage Tolerance	All individual wind turbine generators shall satisfy the dynamic voltage criteria at the POINT(S) OF INTERCONNECTION as specified in Section 2.3. All individual wind turbine generators shall operate continuously if the voltage at the POINT(S) OF INTERCONNECTION is between 0.9 p.u. and 1.10 p.u.
4.2	Frequency Tolerance	All individual wind turbine generators shall satisfy the dynamic frequency criteria at the POINT(S) OF INTERCONNECTION as specified in Section 2.4. They shall operate continuously and remain connected if the frequency is between 59 Hz and 61.5 Hz. INTERCONNECTION STUDIES will determine if modifications to the over frequency limits are permitted or required based on the POINT(S) OF INTERCONNECTION.
4.3	Power Control	The MH SYSTEM OPERATOR shall be able to at all times contact the wind generating facility operator to issue a directive to reduce or curtail the output of the FACILITY(IES) in the event of an emergency condition on the transmission system (Section 3.15). The wind plant shall be able to curtail within 5 minutes. A minimum power ramp rate of 20 MW/minute and the ability to reduce to 0 MW in 5 minutes is required. Reduction amounts, curtailments and ramp rates are specified by the MH SYSTEM OPERATOR. The maximum output of the GENERATOR FACILITY(IES) shall be specified in the IOA. When in operation, the GENERATOR FACILITY(IES) shall not exceed this maximum output value.
4.4	Reactive Power Capability/Control	A wind generating facility shall be able to operate between +0.95 and -0.95 power factor when it is generating its rated name plate capacity measured at the POINT(S) OF INTERCONNECTION. Refer to Figure 5 in Section 8. The reactive power capability shall be sufficient to ensure both steady state and transient stability during and after a disturbance. INTERCONNECTION STUDIES will determine the appropriate amount of dynamic reactive power on a site by site basis. The reactive supply shall be available over the full range of operating conditions. The use of mechanically-switched reactors or capacitors, static var compensators or similar devices may be acceptable alternatives for providing all or part of the reactive supply as shown in Figure 5 in Section 8, and verified by the INTERCONNECTION STUDIES.

No.	Item	Requirement	
4.5	Induction Generator Controls	4.5.1 Voltage Regulation	<p>A continuously acting voltage regulator equipped with a line drop compensator or equivalent providing a minimum of 60% line drop compensation shall be required for each GENERATOR FACILITY(IES) rated larger than 10 MW. The voltage regulator shall have the capability to maintain the steady-state voltage within $\pm 0.5\%$ of the set point at the POINT(S) OF INTERCONNECTION or other control point as determined by the MH SYSTEM OPERATOR. Voltage regulator operation shall be stable and transient gain reduction shall not be used to preserve control system stability. The voltage response time will depend on results from INTERCONNECTION STUDIES, but shall not be greater than 100 milliseconds.</p> <p>A GENERATOR FACILITY(IES) interconnected to the MH TRANSMISSION SYSTEM that is not equipped with a voltage regulator, may be required to install a voltage regulator if SUBSTANTIAL MODIFICATIONS, as defined in Section 1.3, are undertaken. MH will determine the need for a voltage regulator based on the results of the INTERCONNECTION STUDIES.</p> <p>A GENERATOR FACILITY(IES) relying on mechanically-switched shunt capacitors for steady-state voltage regulation shall have the capacitor banks equipped with “rapid discharge” circuits capable of rendering the capacitors available for re-insertion within 5 seconds of de-energization. Additional switched shunt capacitors could be added as an alternative to “rapid discharge” such that the full rating is available for re-insertion. The voltage response time of mechanically-switched capacitor banks shall be adjustable and shall not be greater than 15 seconds. INTERCONNECTION STUDIES will determine if this type of voltage regulation is permissible.</p> <p>The MH SYSTEM OPERATOR will determine the voltage control set point.</p>
		4.5.2 Frequency Response	<p>At present, a wind generating facility does not have to respond to dynamic changes in system frequency as required by synchronous generators in Section 3.9.1. INTERCONNECTION STUDIES will monitor the impact of wind generating facilities to ensure the MH Underfrequency Load Shed Program is not affected. MH reserves the right to require some form of frequency response be included with future wind generating facilities.</p>

No.	Item	Requirement
		<p data-bbox="561 310 1453 569">4.5.3 Power Ramp Rates The real power output of the GENERATOR FACILITY(IES) is required to be adjustable during start-up. MH will review the power ramp rate to determine if there are impacts on the MH TRANSMISSION SYSTEM. The MH SYSTEM OPERATOR will determine the power ramp rate. The minute-to-minute variation in the GENERATOR FACILITY(IES) output cannot exceed the MH real time regulating reserve of +/- 40 MW normal or +/- 80 MW occasional.</p> <p data-bbox="561 579 1453 1031">4.5.4 Other Controls An induction type generator, such as may be connected to wind turbines, is not required to be provided with a Power System Stabilizer or be capable of automatic generation control. Two wind plants connected in a radial configuration, as shown in Fig. 7 (Section 8), may require joint var control. The Generator shall design the necessary controls to ensure proper voltage control coordination between the wind generating facilities and provide details to MH to review. Dynamic reactive power devices may be required to be provided with a power system stabilizer to damp mechanical oscillations. The Generator shall design the necessary controls and provide the details to MH for review. MH reserves the right to review other induction generator controls during INTERCONNECTION STUDIES for compliance with MH planning standards.</p>
4.6	Low Voltage Ride-through	<p data-bbox="561 1052 1453 1241">All individual wind turbine generators shall remain in-service and not trip during a normally clearing single, multi-phase or three-phase fault that occurs on the MH TRANSMISSION SYSTEM. This clearing time is dependent upon the interconnection voltage, for interconnections at 230 kV a wind turbine generator shall remain in-service for a 7 cycle 3 phase fault. See Section 2.6.2 for typical clearing timings.</p> <p data-bbox="561 1251 1453 1514">Figure 1 in Section 8 illustrates the low voltage ride through characteristic, measured at the POINT(S) OF INTERCONNECTION. Individual wind turbine tripping is NOT permitted inside the 'blue' region. Individual wind turbines should not trip within the 'green' region however reduced power output is permissible. Once the voltage recovers from the 'green' region to the 'blue' region, the wind turbine power output should return to its original value within the power gradient limits determined in Section 4.5.3. Individual wind turbine tripping is permitted inside the 'white' region.</p> <p data-bbox="561 1524 1453 1619">The low voltage ride through curve applies for all faults including unbalanced faults, thus the turbine is expected to ride through significantly unbalanced voltages with high negative phase sequence currents of short periods of time.</p> <p data-bbox="561 1629 1453 1724">For prolonged disturbances, where voltage does not recover according to Figure 1, individual wind turbine generators' may be tripped by under-voltage protection. Any shunt capacitors shall also be tripped to prevent over-voltage.</p>

No.	Item	Requirement
4.7	Post Disturbance Recovery	<p>Following a disturbance, a wind generation facility shall return to the pre-disturbance power output, assuming voltage and frequency are within the normal operating range. MVAR output shall respond in a controlled fashion to help system voltage recovery.</p> <p>INTERCONNECTION STUDIES will determine the appropriate post disturbance recovery performance.</p>
4.8	Synchronizing Facilities	<p>Large induction generators (above 1 MW) shall use a mechanical speed matching relay for synchronizing set to accept mechanical speed within +/- 5% of 60 Hz, with an error of less than +/- 2% being preferred. Speed matching is required to ensure that voltage regulation and voltage flicker at the POINT(S) OF INTERCONNECTION are within limits. Magnetizing inrush current may cause voltage drop at the POINT(S) OF INTERCONNECTION even when speed matching is used. The GENERATOR shall be responsible for mitigating excessive voltage drop at the POINT(S) OF INTERCONNECTION caused by induction generator synchronization.</p>

No.	Item	Requirement
4.9	Modelling Data	<p>Along with the requirements specified in Section 3.29, all dynamic models and associated model parameters shall [27]:</p> <ol style="list-style-type: none"> 1. Represent the FACILITY(IES) at the point of interconnection to the accuracy levels described in Section 4.10. 2. Be capable of representing the FACILITY(IES) for all possible power levels including steady state levels. 3. Include unit parameters for equivalent aggregated units. 4. Be derived from the best information available in terms of the actual units being installed 5. Include rotor transients. 6. Be in block format. Dynamic characteristics shall be described by Laplace or Z-transforms. <ol style="list-style-type: none"> a. The blocks should be recognizable in terms of the physical characteristics or component design. b. The blocks should be representative of the elements in the model such that the overall performance element is correctly represented. 7. Include any relevant non-linearities, such as limits, arithmetic or mathematical functions, deadbands or saturation, etc. 8. Include descriptions and setting values for control sequences (e.g. fault ride through control schemes and any other relevant control systems) that are relevant to the intended use of the model. 9. Include any controllers that can adjust the output of the FACILITY(IES) or affect its performance in the time domain simulation timeframe. 10. Have a bandwidth of at least 0.05 – 10 Hz. and shall settle to the correct final value for the applicable system conditions and applied disturbance(s). 11. Not require integration time step sizes less than 2msec. Time constants less than 5msec should only be included if their inclusion is critical to the performance of the model for the purposes described above and in the accuracy requirements describe in Section 4.10.
		<p>Before being allowed to operate, the GENERATOR shall demonstrate by physical performance tests of at least 10% of the wind turbine generators for every type used in the wind plant that the wind turbine generator and voltage regulation perform in agreement with the models provided. Differences between the models and the actual equipment may require that the INTERCONNECTION STUDIES be redone at the GENERATOR’s expense</p> <p>The GENERATOR shall provided updated models as they become available.</p>

No.	Item	Requirement
4.10	Modelling Data Verification	<p>The following criteria will be used to determine what constitutes an accurate simulation model. Models shall accurately represent the performance of the installed equipment at the POINT(S) OF INTERCONNECTION. The model shall respond accurately when compared to the actual equipment response for the same disturbance. During INTERCONNECTION STUDIES the model shall be the manufacture's or GENERATOR'S best expectation of performance that will be verified through commissioning tests.</p> <p>All of the following criteria apply in conjunction and no criteria can override another except were specifically noted [27]:</p> <ol style="list-style-type: none"> 1. The linear response of control system models should be over a frequency bandwidth of at least 0.1 – 5 Hz and must be within the following tolerances: <ol style="list-style-type: none"> a. Magnitude must be within 10% of the actual control system magnitude at any particular frequency. b. Phase must be within 5 degrees of the actual control system magnitude at any particular frequency. 2. Over the frequency range of 0.1 – 5 Hz, the damping of oscillatory modes (i.e. real part of the eigenvalue) should be within 10 % of the actual equipment response. 3. Over the frequency range of 0.1 – 5 Hz, the frequencies of oscillatory modes (i.e. imaginary part of the eigenvalue) should be within 10 % of the actual equipment response. 4. Time domain responses that include non-linear responses or performance, as well as responses to switching or controlled sequence events (e.g. operation of fault ride-through schemes and converter mode changes) the key features of the responses must be within the following tolerances: <ol style="list-style-type: none"> a. Rapid slopes in the response should be within 10%; b. For rapid events or switching events, the size of the peaks and troughs (measured over the total change for that peak or trough) should be within 10% of the change;

		<ul style="list-style-type: none"> c. Oscillations in active power, reactive power and voltage at the point of interconnection, in the frequency range 0.1 – 5 Hz should have damping and frequency oscillation within 10% of the actual equipment response. The phase of the oscillations (relative to the other quantities) must be within 5 degrees in terms of the dominant oscillatory mode. Provided the size of the first cycle of the oscillation meets item 4b., then this item overrides the requirement for subsequent cycles to meet paragraph b.; d. The timing of the occurrence of the rapid slopes, events or the commencement of oscillations described in paragraphs a.-c. must be consistent with the plant characteristic that initiated the response. The response must be explainable and any inconsistency in the response should be investigated to establish plausible reasons for the inconsistency. A revision for the model should be considered if inconsistencies exist. <ol style="list-style-type: none"> 5. At any point during the simulation, the deviation of the model from the actual equipment response for active and reactive power measured at the point of interconnection must not exceed 10% of the total change in that quantity. 6. At any point during the simulation, the deviation of the model from the actual equipment response for voltage measured at the point of interconnection must not exceed 5% of the total change in that quantity. 7. The final active or reactive power value at the point of interconnection at which the model settles following a disturbance is the more restrictive of: <ul style="list-style-type: none"> a. The final value at which the actual equipment would settle to $\pm 2\%$ of the equipment capacity at that point; or b. The final value at which the actual equipment would settle to $\pm 10\%$ of the total change in the quantity during the transient period during and following the disturbance. 8. The final voltage value at the point of interconnection at which the model settles following a disturbance is the more restrictive of: <ul style="list-style-type: none"> a. The final value at which the actual equipment would settle to $\pm 1\%$ of the nominal voltage at that point; or b. The final value at which the actual equipment would settle to $\pm 10\%$ of the total change in voltage during the transient period during and following the disturbance. 9. The model must not show characteristics that are not present in the actual equipment response.
--	--	--

4.11	Special Commissioning Tests	<p>Commissioning/Verifications tests and studies shall be performed to demonstrate that the FACILITY(IES) conforms to all of the interconnection requirements set forth by MH. These test results shall be provided within 30 days following appropriate wind speed conditions to conduct the tests. In particular unless otherwise specified below the field tests shall demonstrate;</p> <ul style="list-style-type: none"> a) The low voltage ride-through capability for each type of turbine controls either by detailed 3 phase fault modelling or by field tests. b) Voltage regulation and reactive power response by demonstrating the ability to control collector and transmission system voltage in a stable manner. The voltage set-point capability may be demonstrated by adjusting the voltage set-point of the voltage regulation system. c) Reactive power control and the ability to provide continuous reactive power: <ul style="list-style-type: none"> • Power factor control (if provided). • Availability of continuous reactive power over the range of voltage and frequency. d) That measured harmonics are within acceptable levels. e) That measured voltage flicker is within acceptable levels. f) The coordination between wind plant protection equipment and system. This may be done by simulation. g) Power ramping and power curtailment. <p>Any type tests or special tests performed by the GENERATOR shall be sealed by a professional engineer. Interconnection will be refused to any wind plant if any tests fail to conform to the interconnection requirements.</p>
4.12	Power Quality	<p>In addition to Section 3.13, voltage flicker shall be assessed during INTERCONNECTION STUDIES as per procedures given in IEC 61400-21 [11]. The GENERATOR shall provide the necessary data which includes but is not limited to flicker coefficients, flicker step factor, and voltage change factor.</p>

4.13	Operational Monitoring and WIND DATA	<p>Sufficient representative wind speed measurement shall be collected from the FACILITY(IES) in order to reasonably estimate wind speeds across the site. A minimum of one full year of measurement collection is needed to quantify energy from a site with sufficient certainty. These data shall be collected from one or more locations that are well-exposed and are expected to be reasonably representative of the winds experienced by the proposed turbines.</p> <p>The acceptable method for assessment of winds across a large project (greater than 20MW) is to install at least one long-term meteorological tower and at the GENERATOR’S discretion use several shorter-term towers to more fully characterize the wind speeds across the project site.</p> <p>Use of SODAR or other techniques without reliable long-term measurements from an on-site meteorological tower is not acceptable. Use of measurements from on-site equipment located on wind turbine towers is not acceptable, except as a means for accounting for brief temporary gaps in long-term meteorological tower data.</p> <p>Whenever possible, wind speeds shall be measured at $\pm 2.5\%$ of the hub height of the turbine expected to be used [25].</p> <p>For towers on a hill, it is necessary to measure wind speeds at more than one height to estimate wind shear on the site. The sensors shall be located at least 15 meters vertically apart and be generally equally unobstructed.</p> <p>Meteorological data shall be sampled every one or two seconds and averaged over not more than a ten-minute period.</p> <p>All measuring equipment (anemometers, wind vanes, air temperature sensors and air pressure sensors) mounted on meteorological masts (met towers) shall meet the technical requirements specified in IEC 61400-12-1 [25].</p> <p>Sufficient anemometry shall be in place to identify periods of tower shading and to identify drifting calibration</p> <p>If a dense canopy of trees is present at the site, the lowest usable sensor shall be located 10 meters above the canopy. At a minimum, at least one vane shall be located on each tower, and temperature measurements shall be available from at least one tower. The temperature sensor shall be a shielded type that is mounted at least one tower diameter away from the tower face to minimize tower heating effects, and oriented on the tower for maximum exposure to the prevailing wind direction to ensure adequate ventilation. Barometric pressure data shall be available, preferably measured on site from at least one tower.</p>
------	--------------------------------------	--

		<p>In addition to Section 2.12 and 3.17, MH requires the following WIND DATA to be delivered to a MH computer in the format specified by MH and a periodicity specified by MH:</p> <ul style="list-style-type: none"> a) Date and time. b) Met tower identification. c) Average wind speed. d) Wind speed variation. e) Wind direction average. f) Wind direction variance g) Temperature h) Pressure i) Relative Humidity. <p>Typically data interval is every 10 minutes.</p> <p>The following information shall be provided by the GENERATOR at time of execution of the Interconnection and Operating Agreement:</p> <ul style="list-style-type: none"> 1. Provide maps showing the locations of all meteorological data collection locations (e.g., met towers), proposed turbine locations, and the site topography. 2. Provide the period of record of data collection for each met tower. 3. Provide, for each met tower, the following information: <ul style="list-style-type: none"> a) Sensor heights. b) Sensor types (manufacturer and model). c) Sensor directions. d) Data averaging interval. (10 minute or lower required) e) Whether sensors were calibrated and what calibrations were applied to data. f) Anemometer slopes and offsets used for the data reduction and documentation of wind speed. g) Height and direction of any nearby obstacles (houses, vegetation, etc.). 4. Identify the companies or organizations responsible for data collection. 5. Describe the sensor mounting arrangements and meteorological tower maintenance program. 6. Describe any variations from the sensor placement and data collection methodologies described above and note any problems that may increase uncertainties in measurements.
--	--	---

		<p>The following electrical data shall be delivered to a MH computer in the format specified by MH and a periodicity specified by MH:</p> <ul style="list-style-type: none"> a) Megawatt and Megavar output. b) Turbine status or number of operational turbines. c) Status of circuit breakers on the transformer and shunt compensation devices. d) The tap position of transformer (voltage regulator setpoint and status). <p>All electrical quantities are to be measured at the point of interconnection</p>
4.14	Protective Equipment and Relaying System Requirements	Additional protection to avoid islanding of the FACILITY(IES) onto local load will be identified during INTERCONNECTION STUDIES.
4.15	Clearances and Access	Energized parts shall be maintained at safe vertical and horizontal clearances that are compliant with the Canadian Electrical Code Part I [19].
4.16	Underground Cables	<p>Underground cables shall be installed in accordance with CSA C22.3 No.7 . MH recommends that the depth of burial should be increased to a minimum of 1.40 meters when cables are placed on agricultural land or in ditches.</p> <p>MH requires that there be no splice located within 3.00 meters of crossing any other utility. MH recommends that all splices be protected with mechanical protection and their location be noted. Splice locations should be marked with electronic buried markers or by GPS coordinates. Refer to CD 205-14 [22].</p>
4.17	Generator Tapping	<p>The default method of tapping an existing transmission line is via a 3-breaker ring, as shown in Figure 6 in Section 8. INTERCONNECTION STUDIES will determine, on a case by case basis, whether a 2-breaker tap may be permitted.</p> <p>Tapping a transmission line with circuit switches will be permitted only for radial lines. Up to two wind generating facilities will be permitted to interconnect to the same radial line provided that there is no customer load on the line. Due to reliability reasons, no customer load will be permitted to tap onto a radial line with a wind generating plant. Refer to Figure 7 in Section 8.</p>

5.0 CUSTOMER LOAD INTERCONNECTION REQUIREMENTS

This section defines the requirements that are applicable for customer loads applying to interconnect to the 66 kV, 115 kV, 138 kV, 230 kV and 500 kV nominal voltage levels on the MH TRANSMISSION SYSTEM or existing customers applying to SUBSTANTIALLY MODIFY their LOAD FACILITY(IES). The CUSTOMER LOAD FACILITY(IES) may contain generation resources for supplying its own loads. If the CUSTOMER LOAD FACILITY(IES) includes such generation resources, then these generation resources are required to satisfy the interconnection requirements for GENERATOR FACILITY(IES) in Section 3.

No.	Item	Requirement
5.1	Interconnection Location and Voltage Level	<p>The CUSTOMER LOAD may apply to interconnect to the MH TRANSMISSION SYSTEM at the nominal voltage levels above 60 kV defined in Section 2.3. It may also be possible to connect at subtransmission voltages below 60 kV as determined by MH.</p> <p>The voltage level and POINT(S) OF INTERCONNECTION to the MH TRANSMISSION SYSTEM shall be determined by MH in consultation with the CUSTOMER LOAD. MH will be the final authority in determining the POINT(S) OF INTERCONNECTION.</p>
5.2	Sealing of Technical Reports, Drawings, Memos, etc.	All reports, memos, drawings, equipment specifications, and modelling data of technical nature (excluding manufacturing drawings) shall be stamped by a Professional Engineer certified to practice in the Province of Manitoba in accordance with <i>The Engineering and Geoscientific Professions Act of Manitoba</i> .
5.3	OPERATING PROCEDURES	The CUSTOMER LOAD shall abide by any OPERATING PROCEDURES, which include one of the following types: TEMPORARY, EMERGENCY OR STANDING OPERATING GUIDES, imposed by the MH SYSTEM OPERATOR.
5.4	Voltage Regulation and Power Factor Requirements	<p>MH reserves the right to operate the MH TRANSMISSION SYSTEM with voltage anywhere within the normal steady-state minimum and maximum voltage operating limits in Section 2.3. The CUSTOMER LOAD shall provide any additional voltage regulation required by the CUSTOMER LOAD FACILITY(IES).</p> <p>Operation of the CUSTOMER LOAD FACILITY(IES) at or near unity power factor is recommended to reduce load-factor demand billing.</p>
5.5	Voltage and Frequency at POINT(S) OF INTERCONNECTION	<p>CUSTOMER LOAD FACILITY(IES) shall be capable of operation over the range of voltage and frequency variation that may occur at the POINT(S) OF INTERCONNECTION, as defined under Sections 2.3 and 2.4.</p> <p>Voltage for rating of equipment to be interconnected to the MH TRANSMISSION SYSTEM is also defined in Section 2.3. MH reserves the right to require the CUSTOMER LOAD's equipment to be capable of operation outside these normal minimum and maximum values defined in Section 2.3 at specific locations on the MH TRANSMISSION SYSTEM.</p>

No.	Item	Requirement	
5.6	Power Quality	5.6.1 Power Quality	The CUSTOMER LOAD FACILITY(IES) and CUSTOMER LOAD INTERCONNECTION FACILITY(IES) shall be designed and operated such that its power quality levels are within the limits specified in PQS2000 [4], “Power Quality Specification For Interconnection to Manitoba Hydro’s Electrical System.”
		5.6.2 Resonance and self-excitation	<p>The CUSTOMER LOAD FACILITY(IES) and CUSTOMER LOAD INTERCONNECTION FACILITY(IES) shall be designed to avoid introducing detrimental resonance into the MH TRANSMISSION SYSTEM.</p> <p>The CUSTOMER LOAD shall assess the risk of self-excitation of any internal GENERATOR FACILITY(IES) or motor load and take appropriate design measures to protect the CUSTOMER LOAD FACILITY(IES) as required.</p> <p>MH will provide the CUSTOMER LOAD with harmonic impedance characteristics of the MH system at the POINT(S) OF INTERCONNECTION on request.</p> <p>The CUSTOMER LOAD shall provide MH with plans for remedial measures, and the associated studies to demonstrate that potential resonances can be avoided or mitigated.</p>
5.7	Protection Requirements	<p>The CUSTOMER LOAD is responsible for the following:</p> <ul style="list-style-type: none"> • Ensuring that the CUSTOMER LOAD FACILITY(IES) and CUSTOMER LOAD INTERCONNECTION FACILITY(IES) are protected for all operating conditions and for all faults on the MH TRANSMISSION SYSTEM. • Providing protective relaying equipment and systems that shall sense and properly react to failure and malfunction of the CUSTOMER LOAD FACILITY(IES) and CUSTOMER LOAD INTERCONNECTION FACILITY(IES) equipment. The design of protective relaying installations shall be in accordance with accepted ANSI/IEEE C37 standards. MH may require redundant protection if INTERCONNECTION STUDIES demonstrate that a failure of a single protection system component jeopardizes the reliability of the MH TRANSMISSION SYSTEM. The protection shall fully protect the safety of the public and of MH personnel interfacing with the CUSTOMER LOAD FACILITY(IES) and CUSTOMER LOAD INTERCONNECTION FACILITY(IES). • Determining the settings for relays that protect the plant equipment within the CUSTOMER LOAD FACILITY(IES) and CUSTOMER LOAD INTERCONNECTION FACILITY(IES). The protection and associated protection settings for installed equipment shall be coordinated by the CUSTOMER LOAD with the settings of the MH TRANSMISSION SYSTEM protection schemes in the area. MH will provide details of the MH system protection to the CUSTOMER LOAD to facilitate this coordination. 	

No.	Item	Requirement
		<ul style="list-style-type: none"> • Providing MH with information as to the type of protection used and the settings for these protections. MH shall be the final authority on establishing control and protection settings that impact the operation of the MH TRANSMISSION SYSTEM. <p>Fault interrupting devices shall have adequate fault interrupting and momentary withstand ratings to satisfy the short circuit level requirements (see Section 5.16) and shall meet maximum clearing times established by the INTERCONNECTION STUDIES. Typical clearing times are given in Section 2.6.2.</p> <p>INTERCONNECTION STUDIES may require that the CUSTOMER LOAD install additional protection to ensure the reliability of the MH TRANSMISSION SYSTEM is not jeopardized.</p> <p>These protections can include but are not limited to the following:</p> <ul style="list-style-type: none"> • Overvoltage, • Bus Protection, • Breaker failure protection. <p><i>Protection of major apparatus</i></p> <p>All faults and conditions in major apparatus such as transformer banks, reactors, capacitor banks, etc. which have the potential to impact the MH TRANSMISSION SYSTEM shall be cleared quickly and without affecting other system elements unnecessarily. If INTERCONNECTION STUDIES demonstrate the reliability of the MH TRANSMISSION SYSTEM is jeopardized, redundancy may be required. Similarly, if communication equipment is required to provide primary protection for the apparatus protection (e.g. transfer tripping), this shall utilize redundant systems over separate routes. If apparatus is co-terminated with other critical transmission system elements, automatic isolation after a fault shall be considered so as to allow immediate restoration of healthy elements.</p> <p><i>Reverse power protection</i></p> <p>Reverse power protection may be required to prevent undesirable inadvertent power flow into the MH TRANSMISSION SYSTEM if the CUSTOMER LOAD FACILITY(IES) has its own generation interconnected or is interconnected to other systems. INTERCONNECTION STUDIES will determine if such protection is necessary, and the required functionality of the protection system.</p> <p><i>Reverse fault protection</i></p> <p>Reverse fault protection will be required to prevent undesirable backfeed (current or voltage) into faults on the MH TRANSMISSION SYSTEM if the CUSTOMER LOAD FACILITY(IES) has its own generation interconnected or is interconnected to other systems. INTERCONNECTION STUDIES will determine if such protection is necessary, and the required functionality of the protection system.</p>

No.	Item	Requirement
		<p><i>Protection for other installed CUSTOMER LOAD FACILITY equipment.</i></p> <p>Although this area is solely the responsibility of the CUSTOMER LOAD, the protection provided shall be coordinated with the MH TRANSMISSION SYSTEM protection schemes in the area; shall not affect the reliability and security of the MH TRANSMISSION SYSTEM and shall fully protect the safety of the public and of MH personnel.</p> <hr/> <p><i>Auto Isolation</i></p> <p>MH reserves the right to automatically isolate CUSTOMER LOAD INTERCONNECTION FACILITY(IES) that includes a GENERATOR FACILITY(IES) to avoid isolation of the GENERATOR FACILITY(IES) on other CUSTOMER LOAD FACILITY(IES) following loss of the high voltage supply connection.</p> <p>Data on the protection and control systems including settings shall be provided to MH as described in Section 7.2.</p>
5.8	Underfrequency Load Shed (UFLS)	<p>MH reserves the right to require all CUSTOMER LOAD FACILITY(IES) to participate in MH's UFLS program described in Section 2.7.</p> <p>The requirement for load shedding is defined in terms of a percentage of total load and, within reason; the CUSTOMER LOAD will determine which of the loads they want to be included in the load shed plan so long as the total load shed meets the required target. MH shall supply and maintain UFLS relays located within the CUSTOMER LOAD FACILITY(IES). CUSTOMER LOAD shall install the UFLS provided by MH. MH will provide the settings for the UFLS relays.</p> <p>Due to the potentially rapid decay in system frequency, the tripping shall not be intentionally delayed. Any significant delays in tripping would defeat the coordination between load shedding set points or the entire program. Operating time to disconnect an individual load point shall not exceed 14 cycles (233 ms) based on a 6 cycle relay time and 8 cycle circuit breaker operating time.</p> <p>Currently some customers own UFLS relays. It is the responsibility of the CUSTOMER LOAD to routinely test their UFLS relays. Testing of these relays does not require live tripping of equipment for routine maintenance. A test schedule and test results shall be provided to MH on request. MH reserves the right to inspect UFLS equipment with the CUSTOMER LOAD FACILITY(IES) to verify settings and operability. MH shall provide reasonable notice to the CUSTOMER LOAD of the proposed date for any planned inspection visits.</p>
5.9	Undervoltage Load Shed (UVLS)	<p>MH reserves the right to require the CUSTOMER LOAD FACILITY(IES) to participate in an UVLS program. The UVLS scheme shall be subject to the requirements determined by MH during INTERCONNECTION STUDIES.</p> <p>The MH shall supply and maintain UVLS relays located within the CUSTOMER LOAD FACILITY(IES). CUSTOMER LOAD shall install the UVLS provided by MH. MH will provide the settings for the UVLS relays.</p>

No.	Item	Requirement	
5.10	Load Restoration	<p>In most cases, the loads will be restored following UVLS and UFLS through supervisory control, or after being authorized by the MH SYSTEM OPERATOR. Automatic restoration may be permitted once system frequency has stabilized for a fixed length of time (e.g. 60 ±0.2 Hz for 5 minutes) in locations with no remote supervisory control and no local operators. The operator of the CUSTOMER LOAD FACILITY(IES) shall get confirmation from the MH SYSTEM OPERATOR before restoring loads, as placing large loads back on the system before adequate generation is restored could result in further system degradation.</p> <p>The MH SYSTEM OPERATOR will be the authority regarding permission to install automatic load restoration devices.</p>	
5.11	Line Auto-Reclosing	<p>Line auto-reclosing is not employed on most of the MH TRANSMISSION SYSTEM above 100 kV. Limited auto-reclosing may be utilized on radial lines, particularly where supervisory control is not available.</p> <p>If required, auto-reclosing may be permitted by MH subject to mitigation of all negative impacts as determined during INTERCONNECTION STUDIES. Subsequent operating experience may require restrictions on auto-reclosing or further mitigation of negative impacts.</p>	
5.12	Revenue Metering	5.12.1 General	<p>All measuring devices and metering equipment required for revenue metering shall be owned, supplied, installed and maintained by MH except as provided under MH Corporate Policy [24].</p> <p>The specific types of metering equipment, timing devices, locations of meters, the details of the metering arrangement and the records to be kept shall be compatible with normal MH practice [20] and Corporate Policy and shall be determined by MH in consultation with the CUSTOMER LOAD.</p>

No.	Item	Requirement
		<p>5.12.2 Accuracy</p> <p>Revenue quality metering equipment shall consist of meters approved for revenue metering by Industry Canada. Metering equipment shall be installed, calibrated, repaired, replaced, maintained and tested in accordance with the provisions of <i>The Electricity and Gas Inspection Act</i> [21], <i>Electricity and Gas Inspection Regulations</i>, Measurement Canada and Manitoba Hydro specifications [24].</p> <p>MH requires 3 element metering accuracy for wye circuits and 2 element metering accuracy for delta circuits.</p> <p>Potential and current transformers for revenue metering shall conform to the Standard CAN3-C13-M83 for 0.3 metering accuracy class and be owned by MH. Independent current transformers are required.</p> <p>If the instrument transformers are owned by the CUSTOMER LOAD, the additional secondary windings on voltage transformers or current transformers may be used for other purposes such as protective relaying as long as the burden is not excessive. MH owned instrument transformers may not be used for protection of the CUSTOMER LOAD INTERCONNECTION FACILITY(IES).</p>
		<p>5.12.3 Metering Configuration</p> <p>The following signals are to be provided:</p> <ul style="list-style-type: none"> • Active and reactive power, • Hourly integrated real and reactive power, where required. • Demand power, where required. <p>Instrument Transformers and such other devices or equipment as shall be necessary to give the instantaneous values of kilowatts and kilovars, and an automatic record of kilowatt-hours and kilovar-hours for each clock hour. Metering shall be able to provide monthly accumulated active and reactive power quantities.</p> <p>When there is a possibility of flows of electricity in either direction (i.e. cogeneration installed), dual register metering equipment shall be installed to record metering data for each direction of flow.</p> <p>Two revenue meters may be installed by MH depending if separate rates apply to the purchase of electricity from the CUSTOMER LOAD and to the supply of electricity to the CUSTOMER LOAD or depending on the POINT(S) OF INTERCONNECTION of the generation within the CUSTOMER LOAD FACILITY(IES).</p>
		<p>5.12.4 Energy Losses</p> <p>Metering shall be installed at the POINT(S) OF INTERCONNECTION. Where metering is installed at a different location, the metering shall be compensated for losses to the POINT(S) OF INTERCONNECTION [24].</p>

No.	Item	Requirement
		<p>5.12.5 Meter Reading Revenue meters may be read locally once per month by MH or may be remotely accessed by MH via telephone. Telemetry facilities to transmit monthly and hourly real and reactive power revenue metering data to MH's SYSTEM CONTROL CENTRE or other facility as directed by MH, shall be provided by the CUSTOMER LOAD except as provided under MH Corporate Policy. Telemetered data shall be in a format compatible with MV90 data collection software or other format as specified by MH.</p> <p>5.12.6 Check Metering MH will provide backup metering or check metering if required. Check metering shall not be connected to the instrument transformers used for revenue metering in the CUSTOMER LOAD FACILITY(IES).</p> <p>5.12.7 Meter Seals Meters shall be sealed and the seals may be broken only by an inspector or accredited meter verifier appointed under the <i>Electricity and Gas Inspection Act</i>, R.S.C. 1985, c.E-4 [21] and then only for the purposes of inspection, verification, testing, re-verification or adjustment in accordance with provisions of the <i>Electricity and Gas Inspection Act</i>.</p> <p>5.12.8 Meter Tests Periodically the MH shall specify tests to confirm the accuracy of meters including but not limited to [23]:</p> <ul style="list-style-type: none"> • Instrument transformers. • Meters/data Loggers. • Alarms and Monitoring Facilities. • Communications Test. • General Quality • Site Documentation. • Error Correction Factors • Loss Adjustments. <p>5.12.9 Security Audit The MH shall have the right, upon 48 hours written notice, to audit the site security of the metering installation [23]. This shall include, but not be limited to,</p> <ul style="list-style-type: none"> • Instrument transformers. • Meters/data Loggers.
5.13	Telemetry and Metering, Supervisory Control and Data Acquisition (SCADA)	A GENERATOR FACILITY(IES) within any CUSTOMER LOAD FACILITY(IES) may be required to provide the telemetry and metering of quantities as specified in Section 3.17.

No.	Item	Requirement
5.14	Disturbance Monitoring	<p>If directed by MH, the CUSTOMER LOAD shall provide facilities, at MH expense, for disturbance monitoring in accordance with MH specifications. MH will determine the need for disturbance monitoring during INTERCONNECTION STUDIES.</p> <p>Dynamic Swing Recording data and/or transient fault recording data shall be provided to MH on request to allow post fault analysis of any disturbances that adversely impact the MH TRANSMISSION SYSTEM in order to determine the possible fault cause and remedial action necessary.</p> <p>Information on monitoring facilities typically used by MH is available in Section 2.6.5.</p>
5.15	Communications	<p>Communications facilities are required between the CUSTOMER LOAD FACILITY(IES) and the MH SYSTEM CONTROL CENTRE. The CUSTOMER LOAD shall provide and maintain the required communications from the CUSTOMER LOAD FACILITY(IES) to the site(s) designated by MH. The communications type and performance shall be adequate for its intended use and shall satisfy the requirements further specified herein. Manitoba Hydro will specify the interface at its sites.</p> <p>Communications may be required for but are not limited to:</p> <ul style="list-style-type: none"> • System protection, • Load curtailment to allow participation in MH curtailable rate programs, • Direct tripping or load shedding by UFLS and/or UVLS schemes, • Supervisory control (including associated data acquisition and alarms), • Telemetry, • Operational voice communication, • Facsimile and e-mail communication. <p>The exact requirement for communications, and functional characteristics, will be dependent on the function served and where appropriate by the reliability and/or redundancy defined during INTERCONNECTION STUDIES.</p> <p>Information on MH practice with regard to communications is available in Section 2.6.4 and 2.12.</p> <p>All communications maintenance and planned outages shall be coordinated through MH.</p>
5.16	Insulation Levels	<p>The CUSTOMER LOAD FACILITY(IES) and CUSTOMER LOAD INTERCONNECTION FACILITY(IES) shall comply with CSA standard CAN/CSA C22.3 C71 “Insulation Coordination (Part 1: Definitions, Principles and Rules, Part 2: Application Guide)”.</p> <p>Equipment interconnected to the MH TRANSMISSION SYSTEM on the high voltage side of load transformer(s) should be insulated to at least the basic insulation levels (BIL) applicable to the system nominal voltage defined in Section 2.10, subject to insulation coordination studies. The CUSTOMER LOAD is responsible for conducting insulation coordination studies.</p>

No.	Item	Requirement
5.17	Short Circuit Levels	The CUSTOMER LOAD FACILITY(IES) and CUSTOMER LOAD INTERCONNECTION FACILITY(IES) shall be designed for operation at short circuit (fault) levels that take into account future development of the MH TRANSMISSION SYSTEM. The short circuit levels to be used in the design depend on the POINT(S) OF INTERCONNECTION and future planned development and are available on request from MH.
5.18	Lightning (Surge) Protection	Lightning (Surge) Protection against direct lightning strokes shall be provided for protecting outdoor equipment including transformers forming part of the CUSTOMER LOAD INTERCONNECTION FACILITY(IES).
5.19	Safety	The CUSTOMER LOAD FACILITY(IES) and CUSTOMER LOAD INTERCONNECTION FACILITY(IES) shall comply with safety requirements in the Canadian Electrical Code [19] or other applicable safety standards mandatory within the Province of Manitoba.
5.20	Design Standards	The CUSTOMER LOAD FACILITY(IES) and CUSTOMER LOAD INTERCONNECTION FACILITY(IES) shall be designed to comply with requirements of the Canadian Electrical Code [19] or other applicable provincial codes within the Province of Manitoba.
5.21	Environmental Conditions	Any equipment that can impact the MH TRANSMISSION SYSTEM shall be designed to function safely and reliably under the environmental conditions prevalent at the selected site. In particular, such equipment located outdoors at or near the POINT(S) OF INTERCONNECTION necessary for isolating the CUSTOMER LOAD INTERCONNECTION FACILITY(IES) from the MH TRANSMISSION SYSTEM shall function reliably in extreme cold weather conditions with minimum temperatures as low as -50°C . Where isolating equipment is not designed to operate at minimum temperatures as low as -50°C , then an alternative means of disconnection shall be available suitable to MH.
5.22	Clearances and Access	Energized parts shall be maintained at safe vertical and horizontal clearances that are compliant with the Canadian Electrical Code [19].
5.23	Isolation	The CUSTOMER LOAD shall provide fault interrupting devices and isolating devices at a location(s) defined by MH at or near the POINT(S) OF INTERCONNECTION.

No.	Item	Requirement
		<p>Isolating devices shall be manually operable or motor operated isolation switches that provide visual electrical isolation. The isolation switch shall simultaneously operate all phases (i.e. gang-operated open/close). In some instances, MH may require motor operated isolation switches to allow rapid remote or automatic isolation from the MH TRANSMISSION SYSTEM. The requirement to provide motor operated isolation devices will be determined by MH on a case by case basis. Provision shall also be made for MH to padlock these isolation switches securely in the open position as per the MH Corporate Safety and Occupational Health Rules [12]. MH may install a separate isolation switch outside the customer load facility if 24-hour access to the CUSTOMER LOAD INTERCONNECTION FACILITY(IES) is not available.</p> <p>If the POINT(S) OF INTERCONNECTION is remote from the interconnecting MH substation, then the isolating device(s) shall also have a safety ground switch(es) installed at MH expense on the MH side of the isolating device(s). The need for the safety ground switch(es) will be determined during INTERCONNECTION STUDIES.</p>
5.24	Transformer Connection	<p>The main transformer connection shall be designed to block transmission of triplen harmonic currents and isolate load side and transmission side grounding networks. The transformer connection shall follow MH practice, information for which can be obtained from MH. Typical MH transformer configurations are provided in Section 2.14. MH will approve the connection configuration.</p> <p>Provision of tap changers, if necessary, to allow operation of the CUSTOMER LOAD FACILITY(IES) over the normal steady-state voltage range over which the MH TRANSMISSION SYSTEM is operated (see Section 5.4) is the responsibility of the CUSTOMER LOAD.</p>
5.25	Verification of Load Demand Characteristic Modelling	<p>The representation of the load demand characteristics of large (greater than 1 MVA) CUSTOMER LOAD FACILITY(IES) requires periodic review by MH to ensure accuracy of the demand modelling. The CUSTOMER LOAD is required to co-operate with MH annually in providing updated demand data and carrying out any field tests required to verify load characteristics.</p> <p>The CUSTOMER LOAD shall provide MH with MW/Mvar forecast of load requirements (see Section 7.2) for analysis as follows:</p> <ul style="list-style-type: none"> • Annual forecast of load (gross and net) for next 10 years, • Load composition (see Section 7.2 for details), • Load reactive characteristics. <p>If a GENERATOR FACILITY(IES) exists, detailed unit data shall be provided in accordance with Section 7.1.</p>
5.26	Testing and Maintenance Coordination	<p>The CUSTOMER LOAD shall provide MH planned testing and maintenance work schedules for equipment within the CUSTOMER LOAD FACILITY(IES) and CUSTOMER LOAD INTERCONNECTION FACILITY(IES). MH shall be given advance notification of planned outages for scheduled test and maintenance work where the CUSTOMER LOAD FACILITY(IES) is larger than 20 MVA.</p>

No.	Item	Requirement
5.27	Inspection Requirements	The CUSTOMER LOAD FACILITY(IES) and CUSTOMER LOAD INTERCONNECTION FACILITIES shall be open to inspection by MH, whenever requested, for verification of compliance with this document. MH shall provide reasonable notice to the CUSTOMER LOAD of the proposed date for any planned inspection visits.
5.28	Coordinated Joint Studies	<p>The CUSTOMER LOAD shall cooperate with MH and participate in any coordinated joint studies or investigations required to verify compliance with the requirements in this document.</p> <p>Manitoba Hydro shall use reasonable efforts to coordinate with adjacent Affected Transmission Operators and Affected Transmission Owners in the performance of any studies and the addition of Interconnection System Upgrades that may be necessary on the interconnected systems of Affected Transmission Owners as a result of planned SUBSTANTIAL MODIFICATIONS or additions to existing facilities.</p>
5.29	Notification of New or Modified Facilities	<p>The CUSTOMER LOAD shall give reasonable notice to MH of any planned SUBSTANTIAL MODIFICATIONS or additions to existing facilities impacting the MH TRANSMISSION SYSTEM and obtain MH's approval that the modifications meet interconnection requirements.</p> <p>Manitoba Hydro shall provide notice to any adjacent Transmission Operator and directly interconnected Transmission Owner that may, in the sole discretion of Manitoba Hydro, be affected by planned SUBSTANTIAL MODIFICATIONS or additions to existing facilities. It shall be the responsibility of the interconnected Transmission Owner to determine whether its facilities and/or operations will be affected by the interconnection request and to designate itself as an Affected Transmission Owner for the purposes of the planned SUBSTANTIAL MODIFICATIONS or additions to existing facilities and identify its specific concerns by the date specified by Manitoba Hydro in its notice.</p>

6.0 TRANSMISSION LINE OWNER INTERCONNECTION REQUIREMENTS

This section defines the requirements that are applicable for a NETWORK CUSTOMER or a transmission line owner of an adjacent utility applying to interconnect to the 66 kV, 115 kV, 138 kV, 230 kV and 500 kV nominal voltage levels on the MH TRANSMISSION SYSTEM. Requirements in this section apply to transmission line facilities connecting the MH TRANSMISSION SYSTEM to another transmission system subject to a review of the rules and regulations (i.e. interconnection requirements) of the adjacent transmission system.

No.	Item	Requirement
6.1	Interconnection Location and Voltage Level	<p>The TRANSMISSION LINE OWNER may apply to connect to the MH TRANSMISSION SYSTEM at the nominal voltage levels above 60 kV defined in Section 2.2. It may also be possible to connect at voltages below 60 kV as determined by MH.</p> <p>The voltage level and POINT(S) OF CONNECTION to the MH TRANSMISSION SYSTEM are to be determined by MH in consultation with the TRANSMISSION LINE OWNER. MH will be the final authority in determining the POINT(S) OF INTERCONNECTION.</p>
6.2	Sealing of Technical Reports, Drawings, Memos, etc.	All reports, memos, drawings, equipment specifications, and modelling data of technical nature (excluding manufacturing drawings) shall be stamped by a Professional Engineer certified to practice in the Province of Manitoba in accordance with <i>The Engineering and Geoscientific Professions Act of Manitoba</i> .
6.3	OPERATING PROCEDURES	The TRANSMISSION LINE OWNER shall abide by any OPERATING PROCEDURES, which include one of the following types: TEMPORARY, EMERGENCY OR STANDING OPERATING GUIDES, imposed by the MH SYSTEM OPERATOR.
6.4	Reactive Power Requirements	<p>The TRANSMISSION LINE OWNER INTERCONNECTION FACILITY (IES) shall be designed to provide reactive power supply and absorption capability acceptable to MH as per performance criteria in [1]. The adequacy of such capability shall be demonstrated by the INTERCONNECTION STUDIES and/or the studies associated with a request for transmission service [5].</p> <p>The TRANSMISSION LINE OWNER shall be responsible for providing any necessary reactive power facilities as determined by the above studies.</p>

No.	Item	Requirement	
6.5	Voltage and Frequency at POINT(S) OF INTERCONNECTION	<p>The TRANSMISSION OWNER INTERCONNECTION FACILITY(IES), when interconnected to the MH TRANSMISSION SYSTEM at the applicable system nominal voltage, shall:</p> <ul style="list-style-type: none"> • be capable of remaining in operation and withstanding the voltage and frequency variation that may occur at the POINT(S) OF INTERCONNECTION, as defined under Sections 2.3 and 2.4. • Be capable of operating continuously within the minimum and maximum voltage limits as defined in Section 2.3 as applicable based on the POINT(S) OF INTERCONNECTION. MH reserves the right to require the TRANSMISSION OWNER’s equipment to be capable of operation outside the normal minimum and maximum values defined in Section 2.3 at specific locations on the MH TRANSMISSION SYSTEM. 	
6.6	Transmission Line Design Criteria	6.6.1 Construction Design Criteria	<p>TRANSMISSION LINE OWNER INTERCONNECTION FACILITY(IES) in Manitoba rated 60 kV and higher shall be designed to meet or exceed CSA Standard C22.3 No. 1 Overhead Systems, and shall follow MH practice in selection of weather loadings and overload factors used in the design of transmission line towers and foundations.</p> <p>Outages due to conductor galloping shall be negligible.</p>
		6.6.2 Electrical Loading Design Criteria	<p>TRANSMISSION LINE OWNER INTERCONNECTION FACILITY(IES) in Manitoba electrical loading design criteria shall conform with MH practice.</p>
		6.6.3 External Electrical Effects	<p>TRANSMISSION LINE OWNER INTERCONNECTION FACILITY(IES) in Manitoba shall conform with MH criteria to limit, television interference, audible noise, electromagnetic and electrostatic induction effects and electric field effects.</p> <p>TRANSMISSION LINE OWNER INTERCONNECTION FACILITY(IES) in Manitoba rated 60 kV and above shall be designed to not exceed the radio noise limits specified in CSA Standard CAN3-C108.3 [3].</p>
		6.6.4 Shield Wires	<p>TRANSMISSION LINE OWNER INTERCONNECTION FACILITY(IES) in Manitoba operating voltages of 230 kV or greater shall be provided with overhead shielding.</p> <p>TRANSMISSION LINE OWNER INTERCONNECTION FACILITY(IES) in Manitoba operating voltages of 115 kV or greater shall be provided with overhead shielding when there is a single circuit between substations.</p>
6.7	Power Quality	6.7.1 Power Quality	<p>THE TRANSMISSION LINE OWNER INTERCONNECTION FACILITY(IES) shall be designed and operated such that its power quality levels are within the limits specified in PQS2000 [4], “Power Quality Specification For Interconnection to Manitoba Hydro’s Electrical System.”</p>

No.	Item	Requirement
		<p>6.7.2 Resonance and self-excitation</p> <p>The TRANSMISSION LINE OWNER INTERCONNECTION FACILITY(IES) shall be designed to avoid introducing detrimental resonances into the MH TRANSMISSION SYSTEM.</p> <p>The TRANSMISSION LINE OWNER shall assess the risk of self-excitation of any internal generators or motor load and implement appropriate design measures to protect the TRANSMISSION LINE OWNER INTERCONNECTION FACILITY(IES) as required. The TRANSMISSION LINE OWNER shall work in consultation with MH to determine an appropriate solution.</p> <p>MH will provide the TRANSMISSION LINE OWNER with harmonic impedance characteristics at the POINT(S) OF INTERCONNECTION on request. The TRANSMISSION LINE OWNER shall ensure that any issues related to resonance and self-excitation are addressed in the TRANSMISSION LINE OWNER INTERCONNECTION FACILITY(IES) design.</p>
6.8	Protection systems	<p>Information on the MH TRANSMISSION SYSTEM protection and control practices is provided in Section 2.6.</p> <p>The TRANSMISSION LINE OWNER is responsible for the following:</p> <ul style="list-style-type: none"> • Ensuring that the TRANSMISSION LINE OWNER INTERCONNECTION FACILITY(IES) is protected for all operating conditions and for all faults on the MH system. • Installing protective relaying equipment and systems that will sense and properly react to failure of equipment and to faults on the TRANSMISSION LINE OWNER INTERCONNECTION FACILITY(IES). Main and backup protective relaying systems are required on TRANSMISSION LINE OWNER INTERCONNECTION FACILITY(IES). The protection shall fully protect the safety of the public and of MH personnel interfacing with the TRANSMISSION LINE OWNER INTERCONNECTION FACILITY(IES). • Determining the settings for relays that protect the TRANSMISSION LINE OWNER INTERCONNECTION FACILITY(IES). The protection and associated protection settings for installed equipment shall be coordinated by the TRANSMISSION LINE OWNER with settings of the MH TRANSMISSION SYSTEM protection schemes in the area. MH will provide details of the MH system protection to the TRANSMISSION LINE OWNER to facilitate this coordination.
		<ul style="list-style-type: none"> • Providing MH with information as to the type of protection used and the settings for these protections. MH in consultation with the TRANSMISSION LINE OWNER will develop control and protection settings to minimize impact of the TRANSMISSION LINE OWNER INTERCONNECTION FACILITY(IES) on the operation of the MH TRANSMISSION SYSTEM.

No.	Item	Requirement
		<p>Fault interrupting devices shall have adequate fault interrupting and momentary withstand ratings to satisfy the short circuit level requirements (see Section 6.16) and shall meet maximum clearing times established by the INTERCONNECTION STUDIES. Typical clearing times are given in Section 2.6.2.</p> <p>INTERCONNECTION STUDIES conducted by MH may require that the TRANSMISSION LINE OWNER installs additional protection for the TRANSMISSION LINE OWNER INTERCONNECTION FACILITY(IES) so as not to jeopardize the reliability of the MH TRANSMISSION SYSTEM.</p> <p>These protections can include but are not limited to the following:</p> <ul style="list-style-type: none"> • Fully redundant protection systems, including associated communication facilities, such that no single protection system component failure will prevent required operation, • Overvoltage protections, • System stability protections such as out-of-step or underfrequency. <p>Data on the protection and control systems including settings as defined in Section 6.3 shall be provided to MH.</p>
6.9	Reclosing	<p>Auto-reclosing is not employed on most of the MH TRANSMISSION SYSTEM at 100 kV and above. Limited auto-reclosing may be utilized on radial feeds, particularly where supervisory control is not available.</p> <p>If required, auto-reclosing may be allowed by MH subject to mitigation of all negative impacts as determined by INTERCONNECTION STUDIES. Subsequent negative operating experience may cause MH to re-evaluate the use of auto-reclosing.</p>

No.	Item	Requirement	
6.10	Synchronizing	<p>Synchro-check functionality is required on all 500 kV and 230 kV circuit breakers. MH will determine if the synchro-check functionality is required on 66 kV, 115 kV and 138 kV circuit breakers during INTERCONNECTION STUDIES.</p> <p>The TRANSMISSION LINE OWNER shall provide synchronizing facilities including a facility for backup manual synchronizing. Manual/remote synchronizing capability shall be provided where required for system switching and restoration. MH will determine the requirements for manual/remote synchronizing during INTERCONNECTION STUDIES.</p> <p>Synchronizing shall normally be accomplished through the closing of a circuit breaker under the control of an automatic synchronizer with automatic voltage and speed matching for the incoming generator so as to achieve a “bumpless” connection with minimum disturbance to the MH TRANSMISSION SYSTEM.</p> <p>The TRANSMISSION LINE OWNER shall be responsible for determining the synchronizer settings. Typical settings used by MH are provided in Section 3.10. The TRANSMISSION LINE OWNER shall resolve any adverse effects caused by generator synchronization.</p> <p>The TRANSMISSION LINE OWNER FACILITY(IES) operator is responsible for synchronization of the TRANSMISSION LINE OWNER INTERCONNECTION FACILITY(IES) to the MH TRANSMISSION SYSTEM subject to authorization from the MH SYSTEM OPERATOR.</p>	
6.11	SPECIAL PROTECTION SYSTEMS (SPS) or REMEDIAL ACTION SCHEMES (RAS)	<p>The TRANSMISSION LINE OWNER INTERCONNECTION FACILITY(IES) shall be provided with capability of being direct tripped. INTERCONNECTION STUDIES may require implementation of SPS or RAS schemes, which require the tripping of transmission line facilities. Such requirements may be imposed at any time as dictated by the requirements of the MH TRANSMISSION SYSTEM. Design of the tripping schemes may be subject to the requirements defined for SPS [1].</p>	
6.12	Revenue Metering	6.12.1 General	<p>All measuring devices and metering equipment required for revenue metering shall be owned, supplied, installed and maintained by MH at MH’s expense, subject to negotiation with the TRANSMISSION LINE OWNER. Metering shall conform to the Transmission Owners Customer Metering Standards [20].</p> <p>The specific types of metering equipment, timing devices, locations of meters, the details of the metering arrangement and the records to be kept shall be compatible with normal MH practice and shall be determined by MH in consultation with the TRANSMISSION LINE OWNER.</p>

No.	Item	Requirement
		<p>6.12.2 Accuracy</p> <p>Revenue quality metering equipment shall consist of meters approved for revenue metering by Industry Canada. Metering equipment shall be installed, calibrated, repaired, replaced, maintained and tested in accordance with the provisions of <i>The Electricity and Gas Inspection Act</i> [21], <i>Electricity and Gas Inspection Regulations</i>, Measurement Canada and Manitoba Hydro specifications [24].</p> <p>MH requires 3 element metering accuracy for wye circuits and 2 element metering accuracy for delta circuits.</p> <p>Potential and current transformers for revenue metering shall conform to the Standard CAN3-C13-M83 for 0.3 metering accuracy class. Independent current transformers are required. Additional secondary windings on voltage transformers may be used for other purposes such as protective relaying as long as the burden is not excessive.</p>
		<p>6.12.3 Metering Configuration</p> <p>The following signals are to be provided:</p> <ul style="list-style-type: none"> • Active and reactive power, • Hourly integrated real and reactive power, where required. • Demand power, where required. <p>Instrument Transformers and such other devices or equipment as shall be necessary to give the instantaneous values of megawatts and megavars, and an automatic record of kilowatt-hours and megavar-hours for each clock hour. Metering shall be able to provide monthly accumulated active and reactive power quantities.</p> <p>When there is a possibility of flows of electricity in either direction, dual register metering equipment shall be installed to record metering data for each direction of flow.</p>
		<p>6.12.4 Energy Losses</p> <p>Metering shall be installed at the POINT(S) OF INTERCONNECTION. Where metering is installed at a different location, the metering shall be compensated for losses to the POINT(S) OF INTERCONNECTION.</p>
		<p>6.12.5 Meter Reading</p> <p>Revenue meters may be read locally once per month by MH or may be remotely accessed by MH via telephone. Telemetry facilities to transmit monthly and hourly real and reactive power revenue metering data to MH's SYSTEM CONTROL CENTRE or other facility as directed by MH, shall be provided by the TRANSMISSION LINE OWNER. Telemetered data shall be in a format compatible with MV90 data collection software or other format as specified by MH.</p>

No.	Item	Requirement
		<p>6.12.6 Check Metering</p> <p>MH will provide backup metering or check metering if required, subject to negotiation with the TRANSMISSION LINE OWNER. Check metering shall not be connected to the instrument transformers used for revenue metering in the TRANSMISSION LINE OWNER FACILITY(IES).</p>
		<p>6.12.7 Meter Seals</p> <p>Meters shall be sealed and the seals may be broken only by an inspector or accredited meter verifier appointed under the <i>Electricity and Gas Inspection Act</i>, R.S.C. 1985, c.E-4 [21] and then only for the purposes of inspection, verification, testing, re-verification or adjustment in accordance with provisions of the <i>Electricity and Gas Inspection Act</i>.</p>
		<p>6.12.8 Meter Tests</p> <p>Periodically the MH shall specify tests to confirm the accuracy of meters including but not limited to [23]:</p> <ul style="list-style-type: none"> • Instrument transformers. • Meters/data Loggers. • Alarms and Monitoring Facilities. • Communications Test. • General Quality • Site Documentation. • Error Correction Factors <p>Loss Adjustments.</p>
		<p>6.12.9 Security Audit</p> <p>The MH shall have the right, upon 48 hours written notice, to audit the site security of the metering installation [23]. This shall include, but not be limited to,</p> <ul style="list-style-type: none"> • Instrument transformers. <p>Meters/data Loggers.</p>

No.	Item	Requirement
6.13	Telemetry, Metering, Supervisory Control and Data Acquisition (SCADA)	<p>The TRANSMISSION LINE OWNER shall provide a Remote Terminal Unit capable of exchanging SCADA information with the MH SYSTEM CONTROL CENTRE. The protocol for data exchange via the Remote Terminal Unit shall be compatible with that used for communications by the MH SYSTEM CONTROL CENTRE. MH will provide the TRANSMISSION LINE OWNER with the protocol for data exchange.</p> <p>As a minimum, the TRANSMISSION LINE OWNER shall provide the following data needed by the Supervisory Control and Data Acquisition (SCADA) system:</p> <ul style="list-style-type: none"> • Line MW and Mvar flows including direction at POINT(S) OF CONNECTION, • Status of circuit breaker(s) and isolator(s), • Line voltages at POINT(S) OF CONNECTION, • Status of reactive power compensation and power flow control devices. <p>All measuring devices and metering equipment required for this purpose shall be supplied, installed and maintained by the TRANSMISSION LINE OWNER.</p> <p>Load designated as NETWORK LOAD by a NETWORK CUSTOMER shall provide metering of quantities required by the MH Supervisory Control and Data Acquisition (SCADA) system. The NETWORK CUSTOMER shall own, supply, install and maintain all measuring devices and metering equipment required for this purpose.</p> <p>Signals that may be required include:</p> <ul style="list-style-type: none"> • Load MW and Mvar measured on the high voltage (HV) side of the load transformer(s), • Load transformer(s) HV side breaker(s) and isolator(s) status, • Bus voltage on the load transformer HV side. <p>Generation designated as a NETWORK RESOURCE by a NETWORK CUSTOMER shall be required to provide the telemetry and metering of quantities as specified in Section 3.17.</p>
6.14	Disturbance Monitoring	<p>If directed by MH, the TRANSMISSION LINE OWNER shall provide facilities, at MH expense, subject to negotiation with the TRANSMISSION LINE OWNER, for disturbance monitoring in accordance with MH specifications. MH will determine the need for disturbance monitoring during INTERCONNECTION STUDIES.</p> <p>Dynamic Swing Recording data and/or transient fault recording data shall be provided to MH on request to allow post fault analysis of any disturbances that adversely impact the MH Transmission System in order to determine the possible fault cause and remedial action necessary.</p> <p>Information on monitoring facilities typically used by MH is available in Section 2.6.5.</p>

No.	Item	Requirement
6.15	Communications	<p>Communications facilities are required between the TRANSMISSION LINE OWNER INTERCONNECTION FACILITY(IES) and the MH SYSTEM CONTROL CENTRE. The TRANSMISSION LINE OWNER shall provide and maintain the required communications from the TRANSMISSION LINE OWNER INTERCONNECTION FACILITY(IES) to the site(s) designated by MH. The communications type and performance shall be adequate for its intended use and shall satisfy the requirements further specified herein. MH will specify the interface at its sites.</p> <p>Communications may be required but are not limited to:</p> <ul style="list-style-type: none"> • System protection, • SPECIAL PROTECTION SYSTEMS (SPS) OR REMEDIAL ACTION SCHEMES (RAS), • Supervisory control (including associated data acquisition and alarms), • Telemetry, • Operational voice communication, from a stand alone dedicated voice line that is capable of functioning for up to 12 hours in a system or site shutdown condition or complete loss of station service supply, • Facsimile and e-mail communication. <p>The exact requirement for communications, and functional characteristics, will be dependent on the function served and where appropriate by the reliability and/or redundancy defined during INTERCONNECTION STUDIES.</p> <p>Information on MH practice with regard to communications for transmission line protection is available in Section 2.6.4 and 2.12.</p> <p>All communications maintenance and planned outages shall be coordinated through MH.</p>
6.16	Insulation Levels	<p>TRANSMISSION LINE OWNER INTERCONNECTION FACILITY(IES) in Manitoba shall comply with CAN3/CSA C22.3 C71 “Insulation Coordination Part 1: Definitions, Principles and Rules, Part 2: Application Guide”.</p> <p>The TRANSMISSION LINE OWNER INTERCONNECTION FACILITY(IES) interconnected to the MH TRANSMISSION SYSTEM shall be insulated to at least the basic insulation levels (BIL) applicable to the system nominal voltage defined in Section 2.10, subject to insulation coordination studies. The TRANSMISSION LINE OWNER shall conduct insulation coordination studies.</p>
6.17	Short Circuit Levels	<p>TRANSMISSION LINE OWNER INTERCONNECTION FACILITY(IES) shall be designed for operation at short circuit (fault) levels that take into account future development of the MH TRANSMISSION SYSTEM. The short circuit levels to be used in the design depend on the POINT(S) OF INTERCONNECTION and future planned development and are available on request from MH.</p>
6.18	Safety	<p>The TRANSMISSION LINE OWNER INTERCONNECTION FACILITY(IES) shall comply with safety requirements in the Canadian Electrical Code [19] and all applicable safety standards mandatory within the Province of Manitoba.</p>

No.	Item	Requirement
6.19	Environmental Conditions	Any equipment that can impact the MH TRANSMISSION SYSTEM shall be designed to function safely and reliably under the environmental conditions prevalent at the selected site. In particular, such equipment located outdoors at the POINT(S) OF INTERCONNECTION necessary for isolating the TRANSMISSION LINE OWNER INTERCONNECTION FACILITY(IES) from the MH TRANSMISSION SYSTEM shall function reliably in extreme cold weather conditions with minimum temperatures as low as -50°C .
6.20	Clearances and Access	Energized parts shall be maintained at safe vertical and horizontal clearances as defined in CSA Standard C22.3 No. 1 Overhead Systems for TRANSMISSION LINE OWNER INTERCONNECTION FACILITY(IES) in Manitoba.
6.21	Isolation	<p>The TRANSMISSION LINE OWNER shall provide fault interrupting devices and isolating devices at a location(s) defined by MH at or near the POINT(S) OF INTERCONNECTION.</p> <p>Isolating devices shall be manually operable or motor operated isolation switches that provide visual electrical isolation. The isolation switch shall simultaneously operate all phases (i.e. gang-operated open/close). In some instances, MH may require motor operated isolation switches to allow rapid remote or automatic isolation from the MH TRANSMISSION SYSTEM. The requirement to provide motor operated isolation devices will be determined by MH on a case by case basis. Provision shall also be provided for MH to padlock these isolation switches securely in the open position as per the MH Corporate Safety and Occupational Health Rules [12].</p> <p>If the POINT(S) OF INTERCONNECTION is remote from the interconnecting MH substation, then the isolating device(s) shall also have a safety ground switch(es) installed on the MH side of the isolating device(s). The need for the safety ground switch(es) will be determined during INTERCONNECTION STUDIES.</p>
6.22	Testing and Maintenance Coordination	The TRANSMISSION LINE OWNER shall provide planned testing and maintenance work schedules for equipment within the TRANSMISSION LINE OWNER INTERCONNECTION FACILITY(IES). MH shall be given advance notification of planned outages for scheduled test and maintenance work.
6.23	Protection System Maintenance and Testing	The TRANSMISSION LINE OWNER shall have a protection system maintenance and testing program in place. The TRANSMISSION LINE OWNER shall provide MH with documentation of the protection system maintenance and testing program.
6.24	Inspection Requirements	The TRANSMISSION LINE OWNER INTERCONNECTION FACILITY(IES) in Manitoba shall be open to inspection by MH, whenever requested, for verification of compliance with this document.

No.	Item	Requirement
6.25	Coordinated Joint Studies	<p>The TRANSMISSION LINE OWNER shall cooperate with MH and participate in any coordinated joint studies or investigations required to verify or confirm compliance with the requirements in this document.</p> <p>Manitoba Hydro shall use reasonable efforts to coordinate with adjacent Affected Transmission Operators and Affected Transmission Owners in the performance of any studies and the addition of Interconnection System Upgrades that may be necessary on the interconnected systems of Affected Transmission Owners as a result of planned modifications or additions to existing facilities.</p>
6.26	Notification of New or Modified Facilities	<p>The TRANSMISSION LINE OWNER shall give reasonable notice to MH of any planned modifications or additions to existing facilities impacting the MH TRANSMISSION SYSTEM and obtain MH's approval of the modification plans before proceeding with the work.</p> <p>Manitoba Hydro shall provide notice to any adjacent Transmission Operator and directly interconnected Transmission Owner that may, in the sole discretion of Manitoba Hydro, be affected by planned modifications or additions to existing facilities. It shall be the responsibility of the interconnected Transmission Owner to determine whether its facilities and/or operations will be affected by the interconnection request and to designate itself as an Affected Transmission Owner for the purposes of the planned modifications or additions to existing facilities and identify its specific concerns by the date specified by Manitoba Hydro in its notice.</p>

7.0 TECHNICAL DATA TO BE PROVIDED BY THE FACILITY OWNER

General technical data, including steady-state and dynamics data, is required by MH to enable evaluation of the FACILITY(IES) being added and to allow realistic simulation of the electric behaviour of the components in the interconnected system. Unit-specific dynamics data shall be provided for generators, excitation systems, voltage regulators, turbine-governor systems, power system stabilizers and other associated generation equipment. Field verification of generator unit data as defined in Section 3.29 and load demand characteristics as defined in Section 2.25 will be required. Some of this data may not be initially available to the FACILITY OWNER but shall be submitted to MH as it becomes available. Additional data or resubmission of data based on periodic testing as directed by MH shall be provided to MH by the FACILITY OWNER.

7.1 Generator Facility Technical Data

Name and location of generator			
Map showing facility location			
Electrical single line diagram (s) (showing anticipated connection to customer's new or existing system and/or connection to the transmission system)			
Site layout plan			
Total Plant Capacity			
Number of Units and MVA rating (with all temperature dependencies indicated)			
Energy Source (Hydro, Thermal, Gas, etc.), Type of Generator (synchronous, induction, etc.) and Prime Mover Type (steam turbine, reciprocating etc.)			
Scheduled In-Service Dates			
Generating Unit	Active/Reactive Power Capability Curve (Mvar vs. MW)		
	Open Circuit and Full Load Saturation Curves		
	Generator V Curve		
	Grounding Method (and impedance value if applicable)		
	Synchronous Generator Data detailed in 6.1.2 Induction Generator Data detailed in 6.1.3 Generator with Power Electronic Interface data detailed in 6.1.4		
	Excitation System and AVR	Make, model and type of exciter (AC or DC, rotary, brushless or static etc.)	
		Make, model and type of AVR	
		AVR setting range	
		Block diagram including values of all gains, time constants and limits in IEEE Standard 421.5 model format [9].	
	Power System Stabilizer	Block diagram including values of all gains, time constants, limits and inputs in IEEE standard 421.5 model format [9].	
Prime Mover and Governor	Block diagram including all parameters in IEEE Standard model format.		

Step-up Transformer	Type, make, model	
	MVA rating—Normal	
	MVA rating—Emergency	
	Voltage rating of each winding	
	Connection configuration of each winding	
	Saturation Characteristics	
	Tap changer nominal tap, tap step size and tap range	
	Positive sequence impedance on own base (p.u.) at nominal tap for each winding	
	Zero sequence impedance on own base (p.u.) at nominal tap for each winding	
Circuit Breakers: type, make, model, interrupting capability, continuous current rating, tripping and closing times		
Surge arresters: Type, make, model and rating		
Description of protection and control provided and protection and control block diagrams and schematic drawings		
List of protection and control settings		
Description of interface provided for remote control and monitoring		
Description of facilities for metering and revenue metering		
Description of communication facilities		
Single line diagram and description of station service and auxiliary load		
Scheduled maintenance annual outage requirements		
Forced outage rate—expected design value		
Phase Unbalance (%)		
Individual harmonic or interharmonic voltage distortion (%)		
Total voltage distortion THD (%)		
High frequency harmonic noise maximum balanced IT		
Wind turbine voltage quality data as per IEC 61400-21		

7.1.1 Thermal Turbine-Generator Mechanical Data (100 MVA or larger unit)

Site Name	
Generator Number or Unique Identifier	
Number of lumped rotating masses on the turbine-generator shaft	
Moment of inertia of each lumped mass	
fraction of the total external mechanical torque applied to each lumped mass	
spring constant of the shaft section between each lumped mass	
speed deviation self-damping coefficient for each lumped mass	
Mutual damping coefficient between pairs of lumped masses	

7.1.2 Synchronous Generator Data

Site Name, Generator number or Unique Identifier			
Rated	MVA		
	MW		
	PF		
	kV		
Synchronous Speed (rpm)			
Short Circuit Ratio			
Inertia Constant H (MW-S./MVA) (generator and turbine combined)			
REACTANCES IN PERCENT ON MACHINE OR STATION MVA BASE (Include both saturated and unsaturated reactances)	Potier Reactance X_p		
	Stator Leakage Reactance X_l		
	Negative sequence resistance R_2		
	Zero sequence resistance R_0		
	AT RATED CURRENT	Direct axis synchronous reactance X_d	
		Direct axis transient reactance X'_d	
		Direct axis sub-transient reactance X''_d ¹	
		Quadrature axis synchronous reactance X_q	
		Quadrature axis transient reactance X'_q	
		Quadrature axis sub-transient reactance X''_q ¹	
		Negative sequence reactance X_2	
		Zero sequence reactance X_0	
	AT RATED VOLTAGE	Direct axis synchronous reactance X_d	
		Direct axis transient reactance X'_d	
		Direct axis sub-transient reactance X''_d ¹	
		Quadrature axis synchronous reactance X_q	
		Quadrature axis transient reactance X'_q	
		Quadrature axis sub-transient reactance X''_q ¹	
Negative sequence reactance X_2			
Zero sequence reactance X_0			
Armature dc resistance R_a (ohms at 100°C, per phase)			
Field resistance R_f (ohms at 25°C)			
Direct axis transient short-circuit time constant T'_d (seconds)			
Direct axis sub-transient short-circuit time constant T''_d (seconds)			
Quadrature axis transient short-circuit time constant T'_q (seconds)			
Quadrature axis sub-transient short-circuit time constant T''_q (seconds)			
Direct axis transient open-circuit time constant T'_{do} (seconds)			
Direct axis sub-transient open-circuit time content T''_{do} (seconds)			
Quadrature axis transient open-circuit time constant T'_{qo} (seconds)			
Quadrature axis sub-transient open-circuit time constant T''_{qo} (seconds)			
Armature short-circuit time constant T_a (seconds)			

¹ The ratio X''_d/X''_q is specified as follows: 0.9 > X''_d/X''_q > 1.1

A ratio near unity helps the machine to provide good damping and ensures that following a sudden three-phase short-circuit on the armature terminals of the generator, the second harmonic components of the armature current are reduced.

Loss of full load, Speed rise (transient Delta t)	
---	--

7.1.3 Induction Generator Data

Site Name			
Generator Number or Unique Identifier			
Rated	MVA		
	MW		
	PF		
	kV		
Torque at Synchronous Speed (pu)			
Mechanical Power Used at Synchronous Speed (MW)			
Inertia Constant H (MW-SEC./MVA) (generator and turbine combined)			
REACTANCES IN PERCENT ON MACHINE OR STATION MVA BASE (Include both saturated and unsaturated reactances)	Stator Leakage Reactance X_1		
	Negative sequence resistance R_2		
	Zero sequence resistance R_0		
	AT RATED CURRENT	Synchronous reactance X	
		Transient reactance X'	
		Sub-transient reactance X''	
		Positive sequence reactance X_1	
		Negative sequence reactance X_2	
		Zero sequence reactance X_0	
	AT RATED VOLTAGE	Synchronous reactance X	
		Transient reactance X'	
		Sub-transient reactance X''	
		Positive sequence reactance X_1	
		Negative sequence reactance X_2	
		Zero sequence reactance X_0	
	Transient short-circuit time constant T' (seconds)		
Sub-transient short-circuit time constant T'' (seconds)			
Transient open-circuit time constant T'_o (seconds)			
Sub-transient open-circuit time content T''_o (seconds)			

7.1.4 Non-Standard Generator with Power Electronic Interface Data

Site Name		
Generator Number or Unique Identifier		
Rated	MVA	
	MW	
	PF	
	kV	
Contact MH for specific data submission requirements for this type of generator.		

7.2 Customer Load Facility Technical Data

Name and location of customer load facility			
Map showing facility location			
Electrical single line diagram			
Site layout plan			
Type of Load			
Total Connected Load (MW and MVar)			
Facility scheduled in-service date			
MW/MVAr Forecast of load (gross and net) for 10 years			
Monthly peak hour forecast demand in MW for next 2 years			
Monthly net energy forecast for load in GWh for next 2 years			
Annual peak hour forecast demand (summer) in MW for next 10 years			
Annual peak hour forecast demand (winter) in MW for next 10 years			
Annual net energy forecast for load in GWh for next 10 years			
Details of Load	Interruptibility		
	Phase Unbalance (%)		
	Individual harmonic or interharmonic voltage distortion (%)		
	Total voltage distortion THD (%)		
	High frequency harmonic noise maximum balanced IT		
	Load Composition and Load Data	Furnace Load (Size, usage, load modelling data)	
		Welding Equipment (Size, usage, load modelling data)	
		Motor Loads (for each motor give HP, Type, Function, Starts/day, modelling data; for motors larger than 200 Hp, detailed modelling data is required)	
		Co-Generation (Size, usage; detailed modelling data is required as per Section 6.1)	
		Fluorescent Lighting (Size, usage, load modelling data)	
Other loads (Type, size, usage, rate of fluctuation, load modelling data for each type)			
Step-down Transformer	Type, make, model		
	MVA rating—Normal		
	MVA rating—Emergency		
	Voltage rating of each winding		
	Connection configuration of each winding		
	Saturation Characteristics		
	Tap changer nominal tap, tap step size and tap range		
	Positive sequence impedance on own base (p.u.) at nominal tap for each winding		
	Zero sequence impedance on own base (p.u.) at nominal tap for each winding		
Circuit Breakers: type, make, model, interrupting capability, continuous current rating, tripping and closing times			

Surge arresters: Type, make, model and rating	
Description of protection and control provided including block diagrams and schematic diagrams	
List of protection and control settings	
Description of interface provided for remote control and monitoring	
Description of facilities for metering	
Description of communication facilities	

7.3 Transmission Line Owner Interconnection Facility Technical Data

Overhead Transmission Line	Nominal Voltage (kV)	
	Length (km)	
	Route Map (including transposition locations)	
	Plan and profile drawings	
	Electrical single line diagram showing transmission line and any other associated devices required for switching, reactive compensation, protection and control and communication and the interface to the generator or end-user facility	
	Nominal power transfer rating	
	Emergency power transfer rating	
	Conductor type and size	
	Overhead ground wire type and size	
	Configuration of conductors and overhead ground wires on tower (include diagram showing phase spacing and clearances to ground)	
	Positive Sequence R_1 , X_1 and B_1 (ohms/km)	
	Zero sequence R_0 and X_0 (ohms/km)	
	Description of protections provided	
	Description of communication systems	
	Reactive Compensation device (if applicable)	Connection Location
Type, make, model		
Configuration		
Rated Voltage (kV)		
Size (MVar)		
Switching device: type, make, model, interrupting capability, continuous current rating, tripping and closing times and any switching restrictions		
Criteria for automatic switching		
Description of protections provided		
Intermediate or terminal substation (if applicable)	Electrical single line diagram	
	Circuit Breakers: type, make, model, interrupting capability, continuous current rating, tripping and closing times	
	Description of protections	

Transformer (if applicable)	Type, make, model	
	MVA rating—Normal	
	MVA rating—Emergency	
	Voltage rating of each winding	
	Connection configuration of each winding	
	Saturation Characteristics	
	Tap-changer nominal tap, tap step size and tap range	
	Positive sequence impedance on own base (p.u.) at nominal tap for each winding	
Zero sequence impedance on own base (p.u.) at nominal tap for each winding		
Circuit Breakers: type, make, model, interrupting capability, continuous current rating, tripping and closing times		
Surge arresters: Type, make, model and rating		
Description of protection and control provided including block diagrams and schematic diagrams		
List of protection and control settings		
Description of interface provided for remote control and monitoring		
Description of facilities for metering		
Description of communication systems provided		

8.0 FIGURES.

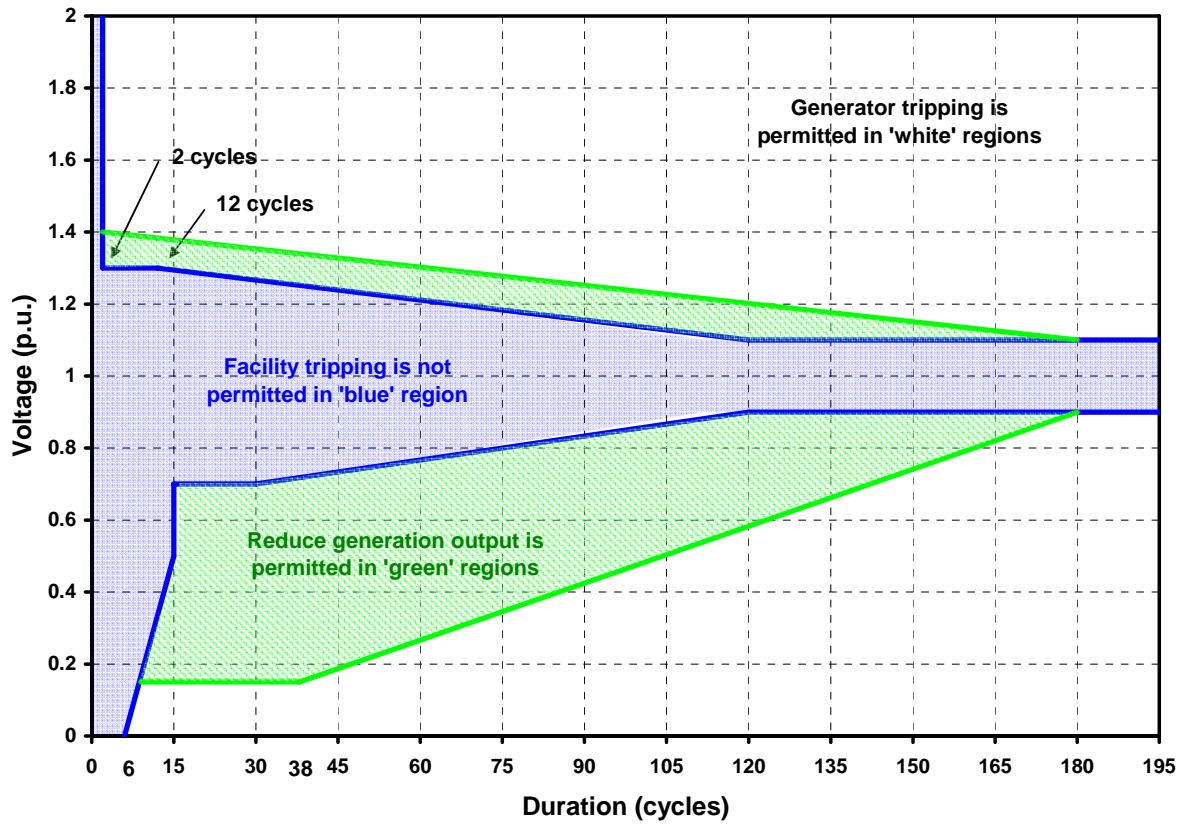

Figure 1: MH dynamic voltage variation criteria for the 230 kV system; Sections 2.4 and 2.7.2. Facility tripping is not permitted inside the blue region.

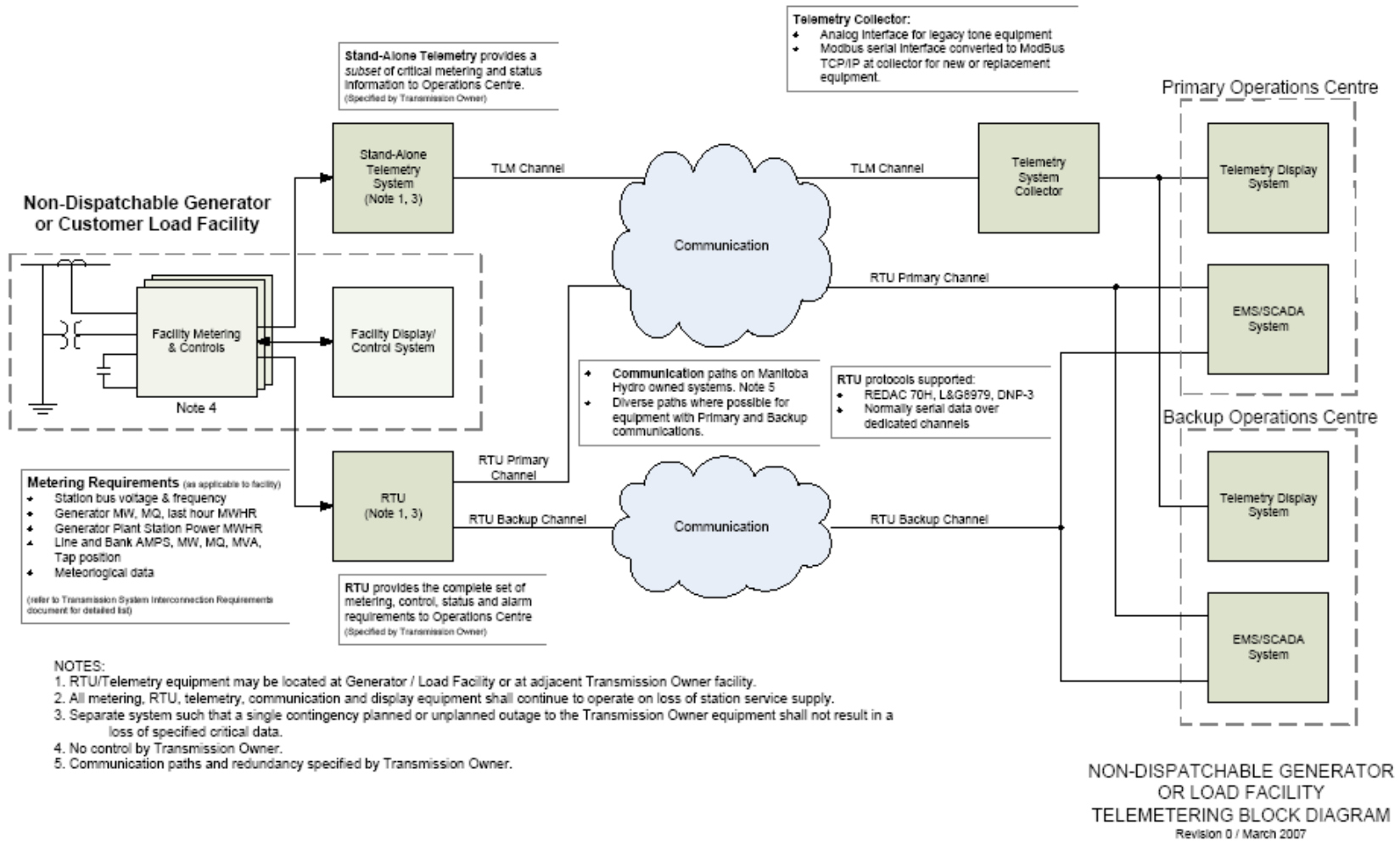

Figure 2: Manitoba Hydro Non-Dispatchable Generator or Load Facility Telemetering Block Diagram.

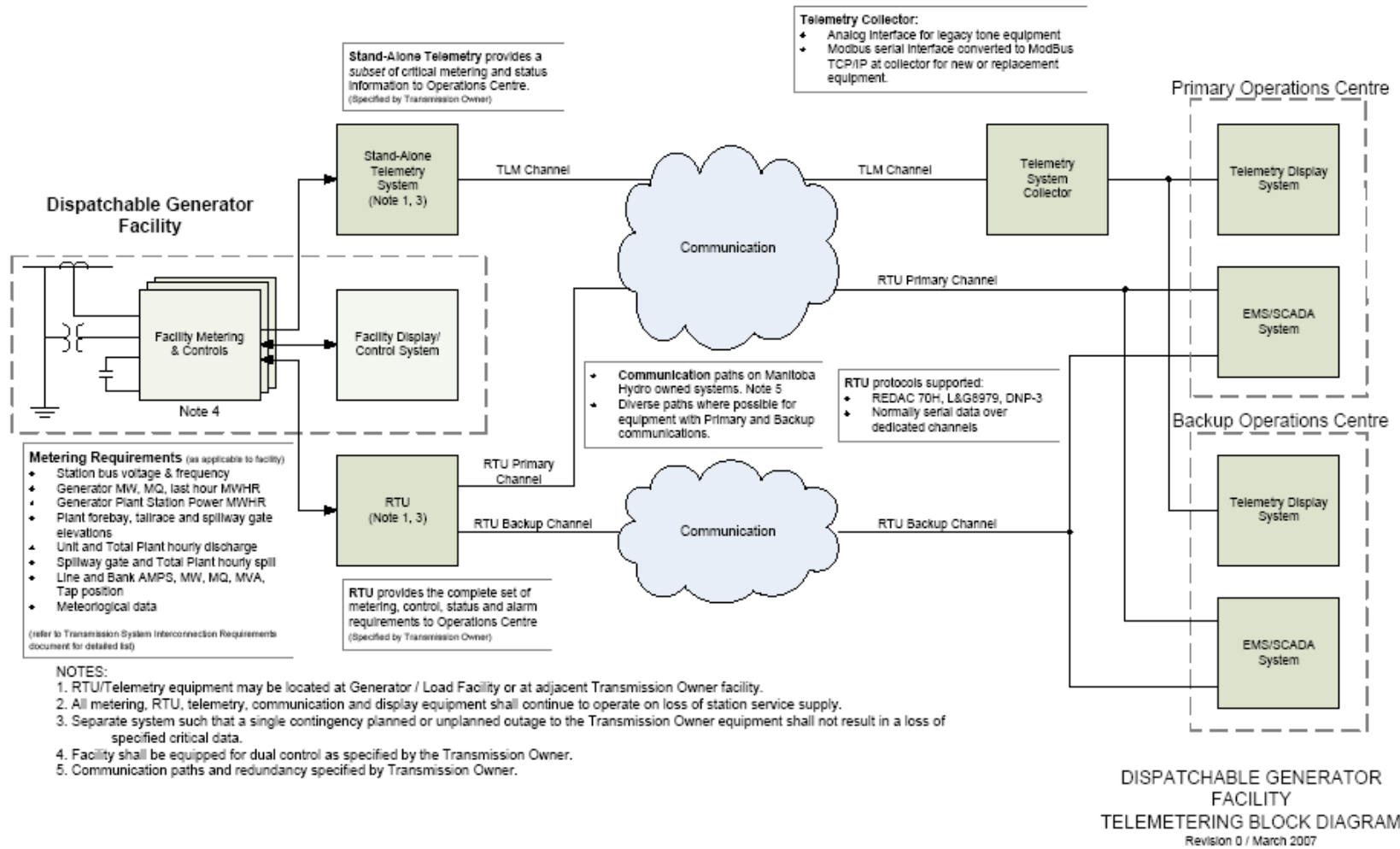

Figure 3: Manitoba Hydro Dispatchable Generator Facility Telemetry Block Diagram

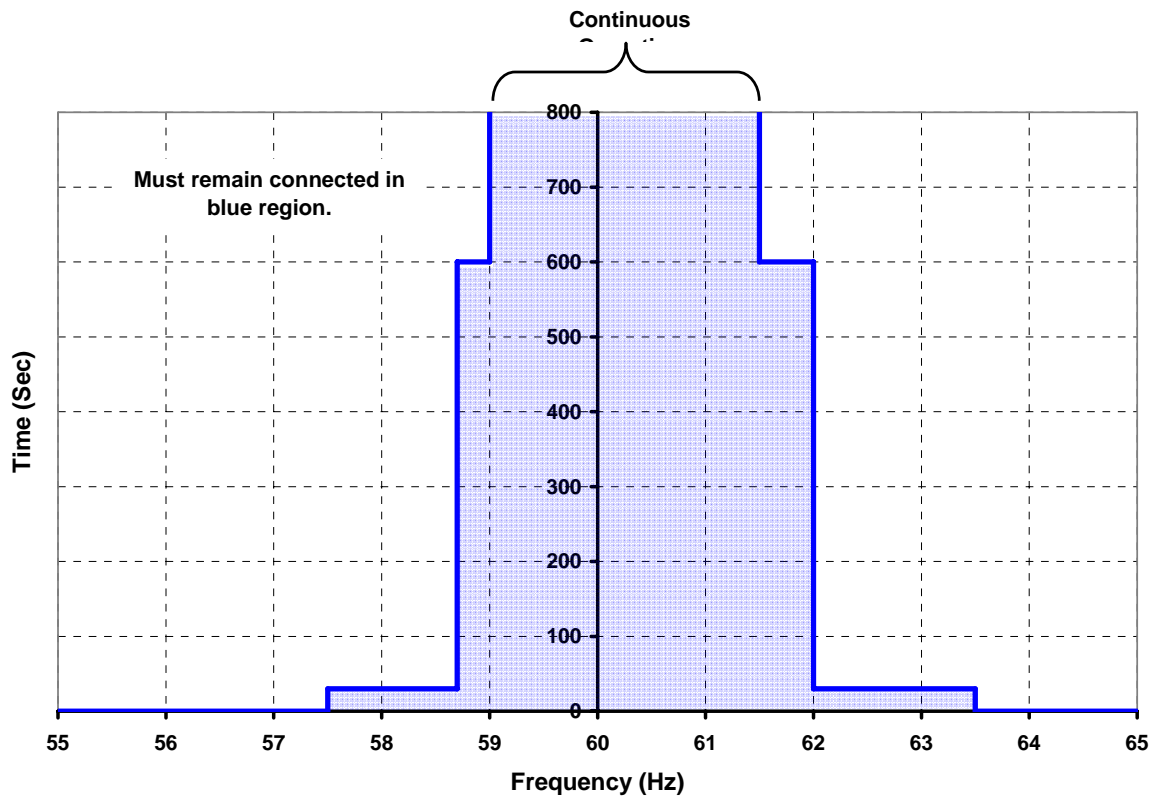

Figure 4: Frequency Tolerance Curve for Generator Units.

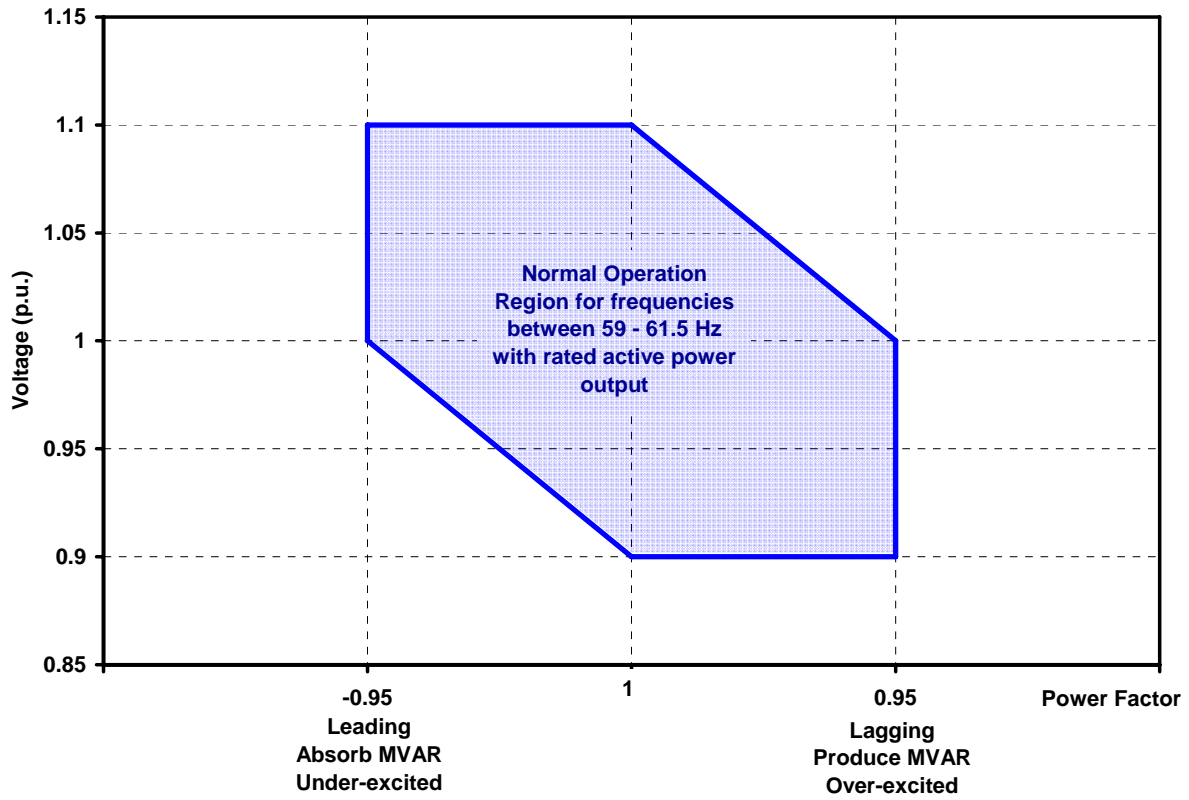

Figure 5: Minimum Reactive Power Requirements for Wind Turbine Generators

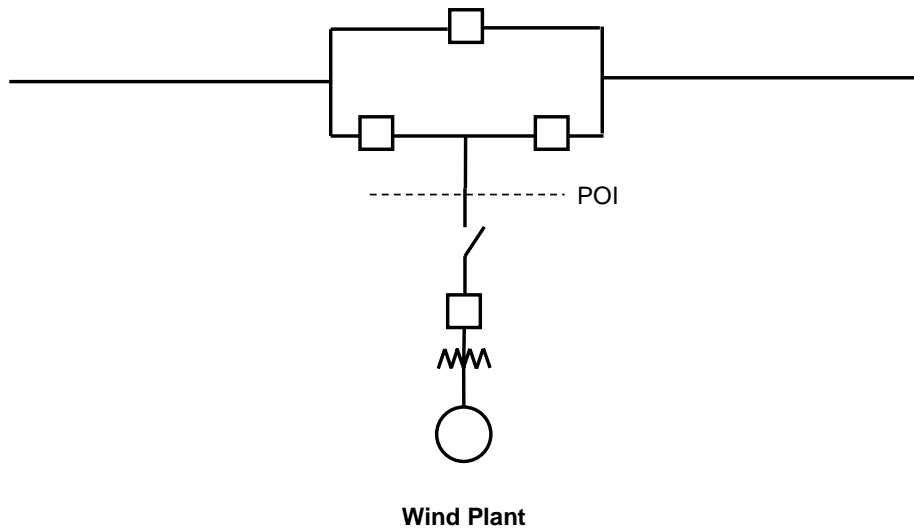

Figure 6: Default tapping configuration. Ring bus required for transmission lines with one or more customer loads or interconnections.

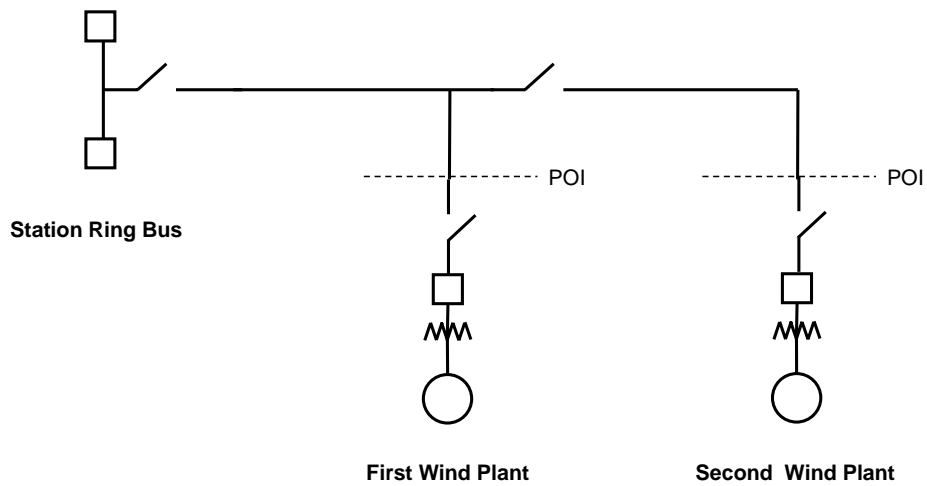

Figure 7: Special radial interconnection permitted for wind generation. Customer load will not be permitted to tap onto this radial configuration.

9.0 REFERENCES

- [1] NERC Reliability Standards issued by the North American Electric Reliability Corporation.
<http://www.nerc.com/>
- [2] MRO Reliability Standards issued by the Midwest Reliability Organization.
<http://www.midwestreliability.org/>
- [3] CSA Standard CAN3-C108.3.1, Limits and Measurement Methods of Electromagnetic Noise from AC Power Systems, 0.15-30 MHz.
- [4] Power Quality Specification for Interconnection to Manitoba Hydro's Electrical System, PQS2000.
http://coil.hydro.mb.ca/Dist_PD_Div/Service_Quality/Index.htm
- [5] MH Open Access Transmission Tariff, available at the web site:
<http://oasis.midwestiso.org/documents/Mheb/tariff.html>.
- [6] MRO Generator Testing Requirements, Midwest Reliability Organization (MRO) - Roseville, MN. Available at the web site: <http://www.midwestreliability.org/>.
- [7] ANSI/IEEE Standard C37.102, "IEEE Guide for AC Generator Protection".
- [8] ANSI/IEEE Standard C62.92, "IEEE Guide for the Application of Neutral Grounding in Electrical Utility Systems Part II—Grounding of Synchronous Generator Systems".
- [9] IEEE Standard 421.5, "IEEE Recommended Practice for Excitation System Models for Power System Stability Studies".
- [10] IEEE Standard 80, "IEEE Guide for Safety in AC Substation Grounding".
- [11] International Standard IEC 61400-21, "Measurement and Assessment of Power Quality Characteristics of grid Connected Wind Turbines".
- [12] Manitoba Hydro Corporate Safety and Occupational Health Rules , available at the web site:
<http://coil.hydro.mb.ca/esh/>.
- [13] Interconnection Guideline for Connecting Distributed Resources to the Manitoba Hydro Distribution System, DRG2003, available at the web site:
<http://oasis.midwestiso.org/documents/Mheb/queue.html>.
- [14] IEEE Standard C57.116,"Guide for Transformers Directly Connected to Generators".
- [15] IEEE Standard 122,"Recommended Practice for Functional and Performance Characteristics of Control Systems for Steam Turbine-Generator Units"
- [16] IEEE Standard 125," Recommended Practice for Preparation of Equipment Specifications for Speed Governing of Hydraulic Turbines Intended to Drive Electric Generators"
- [17] IEEE Standard 421.1,"IEEE Standard Definitions for Excitation Systems for Synchronous Generators"
- [18] IEEE Standard 421.4,"Guide for the Preparation of Excitation System Specifications"
- [19] CSA C22.1, C22.2 and C22.3-Canadian Electrical Code Parts I, II & III.
- [20] MH Customer Metering Standards.
http://www.hydro.mb.ca/customer_services/permits_and_inspections/electrical/inspections.shtml
- [21] Electricity and Gas Inspection Act, R.S.C. 1985, c.E-4 available at the web site:
<http://canada.justice.gc.ca/en/>
- [22] MH Typical Underground Trench Cross-Sections, Direct Buried System, CD 205-14.

- [23] Manitoba Hydro Generator Interconnection Operating Requirements.
<http://oasis.midwestiso.org/OASIS/MHEB>
- [24] Customer Policy Application Manual, General Services Electricity Billing (2110 VI), available at the web site: <http://coil.hydro.mb.ca/cpa/2110vi.htm>
- [25] International Standard IEC 61400-12-1, “Wind Turbines, Part 12-1; Power performance measurements of electricity producing wind turbines”.
- [26] National Electricity Market Management Company Limited, “Wind Farm Model Guidelines and Checklist.”
- [27] IEEE Standard C50.12, “IEEE Standard for Salient-Pole 50 HZ and 60 Hz Synchronous Generators and Generator/Motors for Hydraulic Turbine Applications Rated 5 MVA and Above.”
- [28] IEEE Standard C50.13, “IEEE Standard for Cylindrical-Rotor 50 HZ and 60 Hz Synchronous Generators Rated 10 MVA and Above.”
- [29]

NERC documentation is available at web site <http://www.nerc.com/> and MAPP documentation is available at web site <http://www.mapp.org/>