

Twin Cities Minnesota  
Zone Meeting  
Xcel Energy

May 11, 2005  
Bloomington, MN

# Overview of Presentation

- Xcel Energy Projects:
  - Aldrich to St Louis Park 115 kV line
  - Eden Prairie to Edina 115 kV line
  - Eden Prairie - Minnetonka Area
  - Carver County - Waconia Area
  - Chisago to Apple River Project
  - High Bridge to Rogers Lake 115 kV line
  - Blue Lake generation outlet

# Overview of Presentation

- New Koch to Inver Hills 115 kV line line #2
- Prairie Island to Red Rock 345 kV circuit #2
- Oakdale to Tanners Lake 115 kV line
- Champlin to Champlin Tap to Crooked Lake 115 kV
- New Yankee Doodle 115 kV source
- Twin Cities 345/115 kV transformer capacity
- Twin Cities Fault current issue

# Aldrich-St Louis Park 115 kV

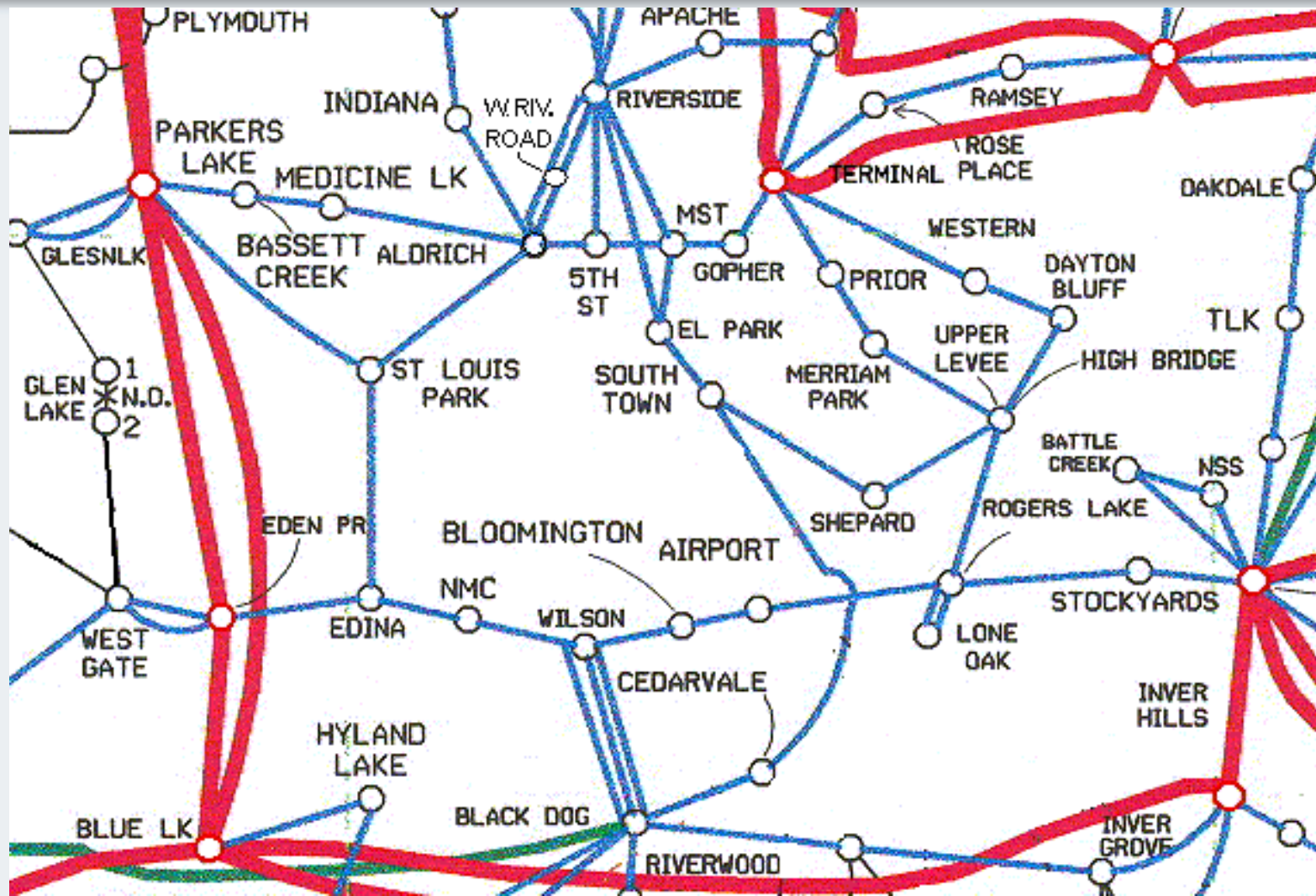

# Aldrich-St Louis Park 115 kV Line

- **Need:**
  - Under some summer peak conditions, the line may overload
  - Worst case outage of the 345 kV double circuit carrying the Parkers Lake-Dickinson line and the Parkers Lake Elm Creek line;
- **Solution:**
  - Re-conductor the line by summer 2006 to enable it to carry more power



# Edina-Eden Prairie 115 kV Line

- **Need:**
  - Under some summer peak conditions, a one mile section of this line may overload
  - Outage of the double circuit carrying the Parkers Lake-Cedar Lake and Parkers Lake-Bassett Creek 115 kV lines
- **Proposed Solution:**
  - Upgrade line to 600 amps by reconductoring 4.7 miles of  
795 ACSR with 795 ACSS
  - Upgrade switch at Edina substation to 3000 amps

# Eden Prairie-Minnetonka Transmission System

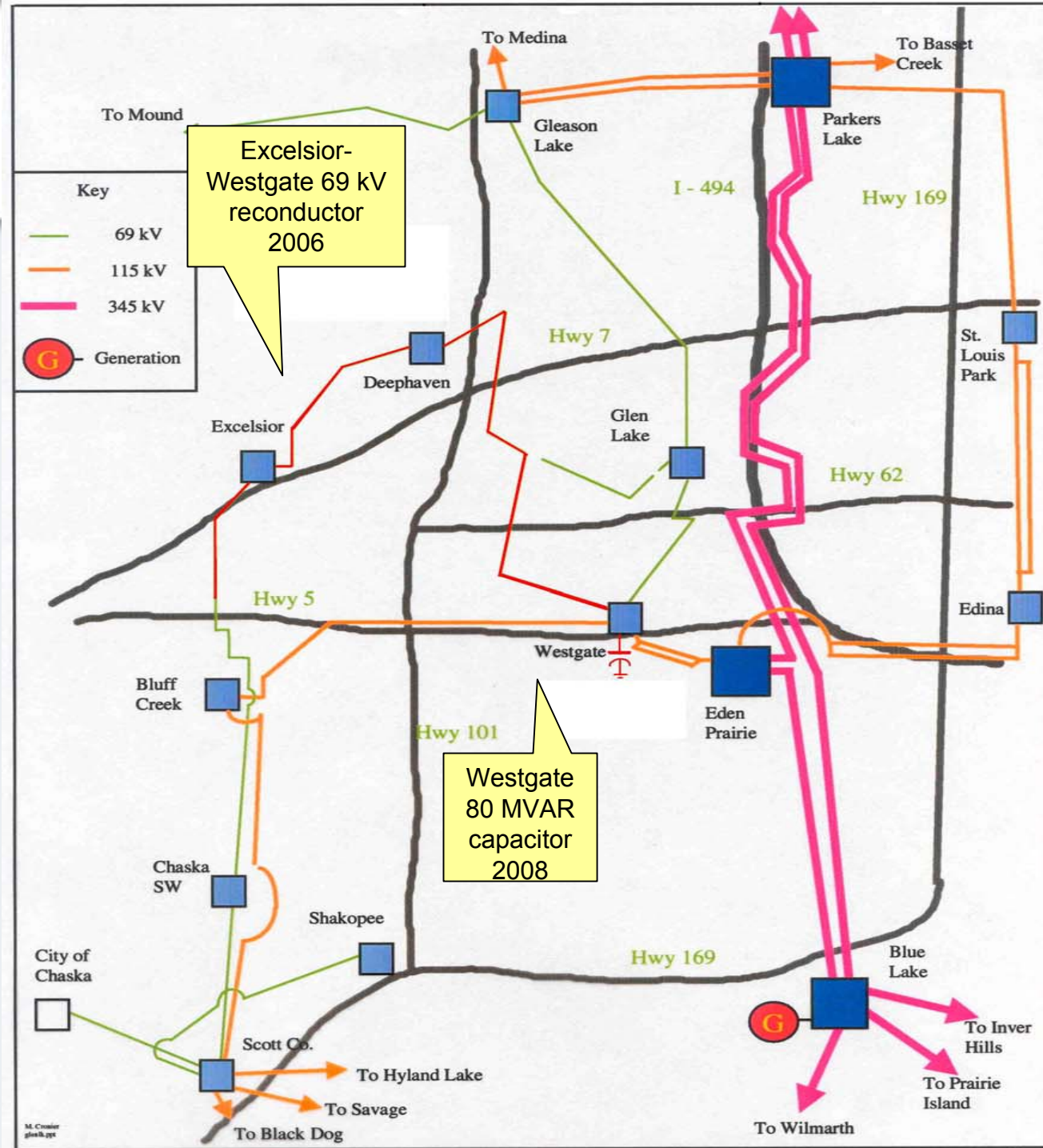

# Eden Prairie-Minnetonka Area

- **Needs:**
  - Outage of Scott County-Chaska 69 kV line overloads Excelsior-Westgate 69 kV line in 2006
  - Outage of Westgate-Eden Prairie 115 kV double circuit line results in low voltage in 2008
  - Outage of Scott County-Chaska 69 kV line overloads the reconductored Excelsior-Westgate 69 kV line in 2011

# Eden Prairie – Minnetonka Area

- Short-term upgrades:
  - Reconductor Excelsior-Deephaven-Westgate 69 kV line and Westgate 115 kV capacitor
  - Expected in-service of 2006 (line) and 2008 (capacitor)
- Long-term upgrade:
  - Scott Co - Westgate 69 kV rebuild to 115 kV (approximately 2011)
  - Will be reviewed again in upcoming twin cities long range studies

# Westgate to Scott County 115 kV line option





# Carver Co - Waconia Area

- **Needs:**

- During summer peak load conditions, the Glencoe-Young America 69 kV line may overload by 2008
- outage of future McLeod-Glencoe 115 kV line

# Carver Co – Waconia Area

- Long-term upgrade options for 2008:
  - Rebuild Glencoe-Carver Co 69 kV line to 115 kV
  - Rebuild Glencoe to West Waconia 69 kV line and reconfigure 69 kV system to 115 kV
  - Expected to begin review studies by end of 2005
  - Plan to file CON Spring 2006

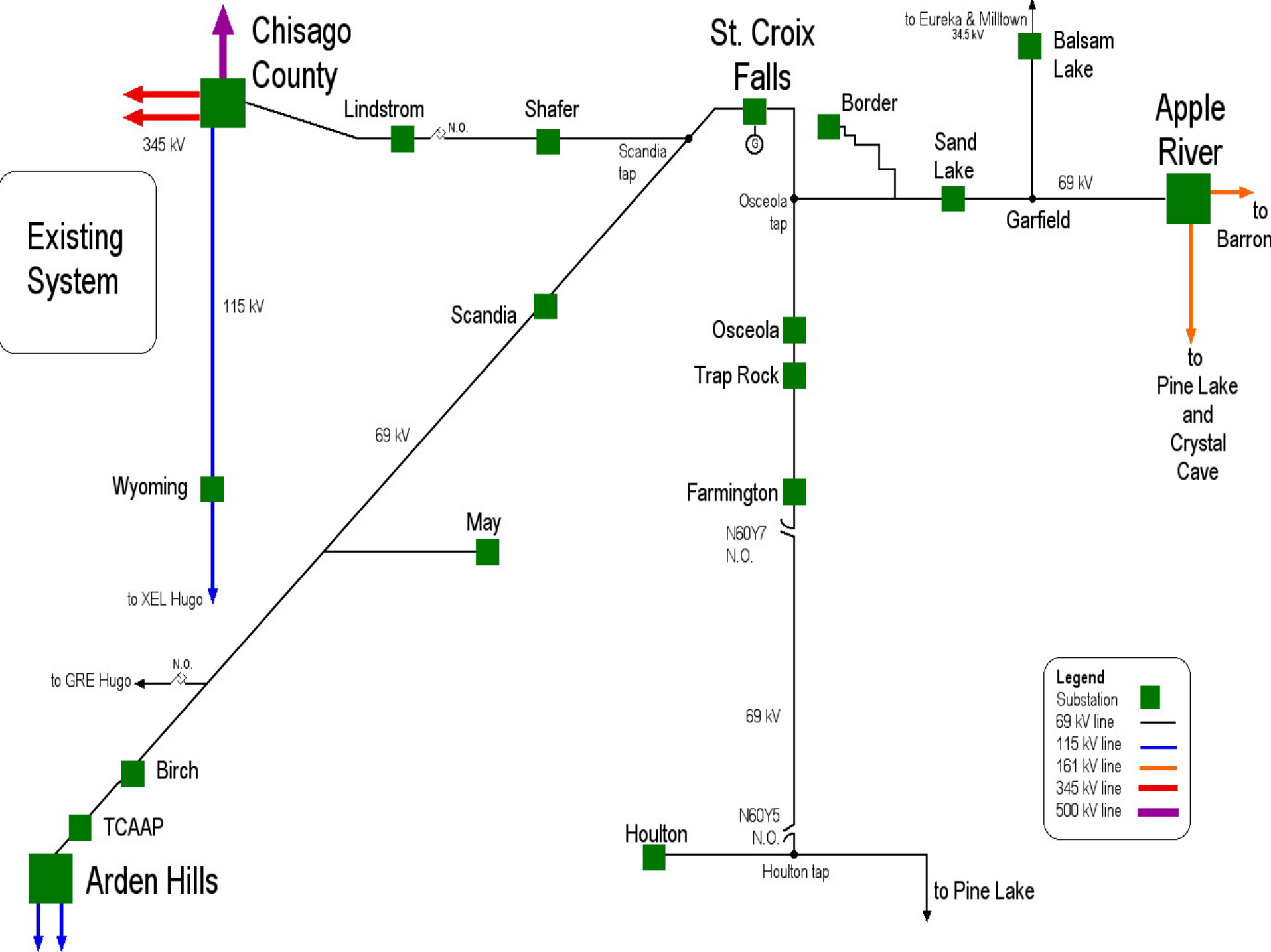

# Chisago – Apple River Project

- **Needs:**

- Outage of Apple River 69 kV source may result in overload of Arden Hills-Birch 69 kV line
- Outage of Apple River 69 kV source may result in low voltage at Shafer, Scandia, and Sand Lake
- Outage of Arden Hills 69 kV source may result in overload of Apple River-Garfield 69 kV line
- Using operating procedures to defer upgrades into the later 2000's.

# Chisago – Apple River Project

- **Options examined:**
  - Chisago-Lawrence Creek 115 kV line and Lawrence Creek-Apple River 161 kV line. Recommended plan
  - Chisago-Apple River 69 kV line rebuild
  - Reconfigure 69 kV system and add reactive support
  - Distributed generation is cost prohibited
- **Update:** Project approved in Wisconsin. Certificate Of Need still needs to be filed in Minnesota

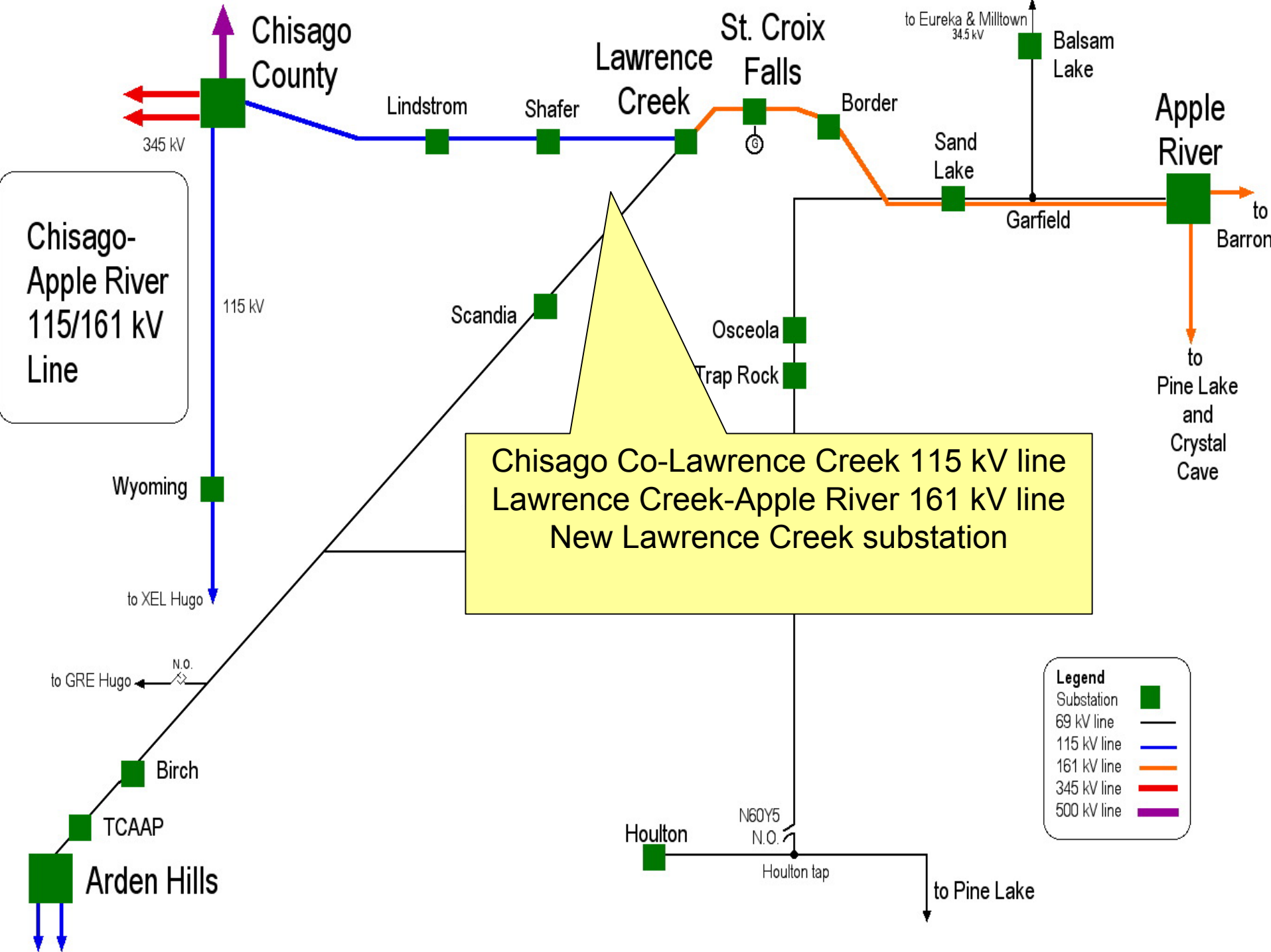

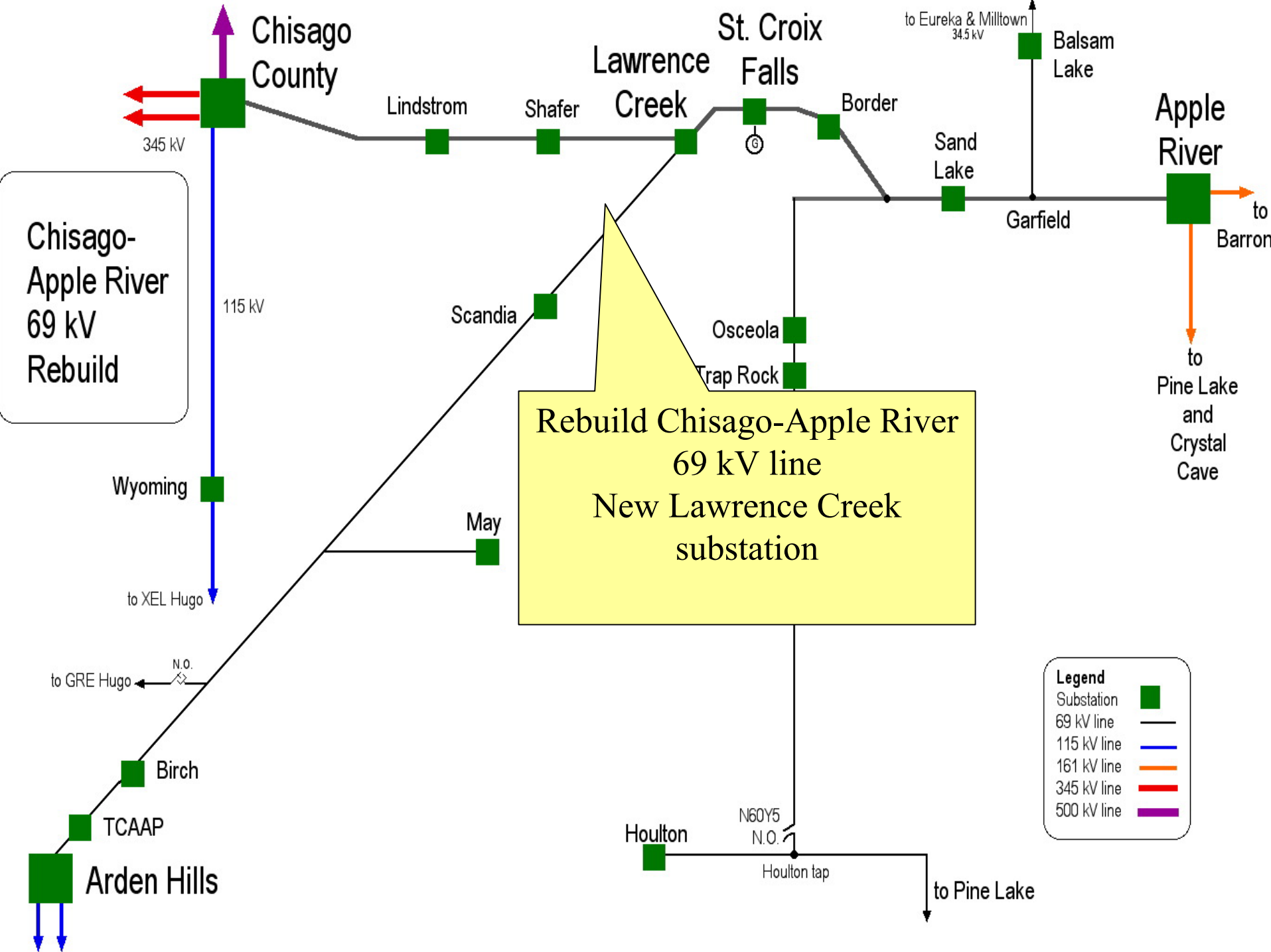

# High Bridge-Rogers Lake 115 kV Line

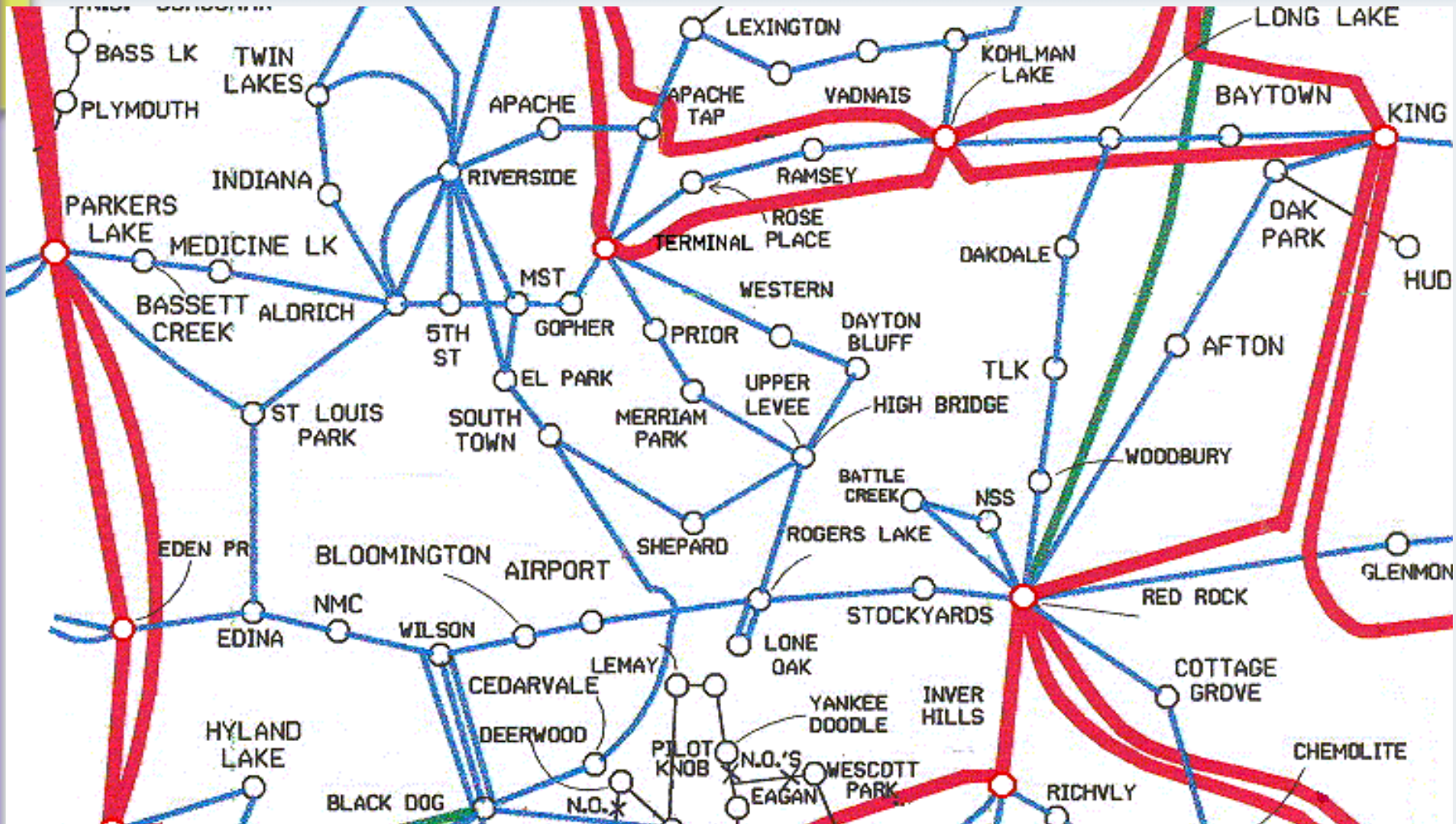

# High Bridge-Rogers Lake 115kV Line

- **Need:**

- This has the potential to overload under certain operating conditions
- Operating procedure: generation redispatch (being reviewed annually)

- **New Factor:**

- High Bridge and Riverside generation are scheduled to be upgraded and converted from coal to gas/steam combined plants as part of the Metropolitan emission reduction program (MERP) in 2008-2009
- High Bridge to Rogers Lake 115 kV line overload is aggravated by the MERP projects

# High Bridge-Rogers Lake 115kV Line

- **Status:**

- MISO is almost completed transmission service request studies for the High Bridge and Riverside generation upgrades
- Found that High Bridge and Riverside generation
- Upgrades cause overload of High Bridge to Rogers Lake 115 kV during certain transmission outages

# Blue Lake Generation Increase Project

- **Need:**
  - Generation increase of about 395 MW at Xcel Energy's Blue Lake Substation in Shakopee
  - Plant is in-service
  - Plant required additional transmission outlet
- **Solution:**
  - Interconnecting to the existing McLeod to Black Dog 230 kV
  - Moved Black Dog 230/115 kV transformer Blue Lake
  - Reconductor 8 miles of Blue Lake to Black Dog 230 kV and operate at 115 kV

# Blue Lake generation increase project

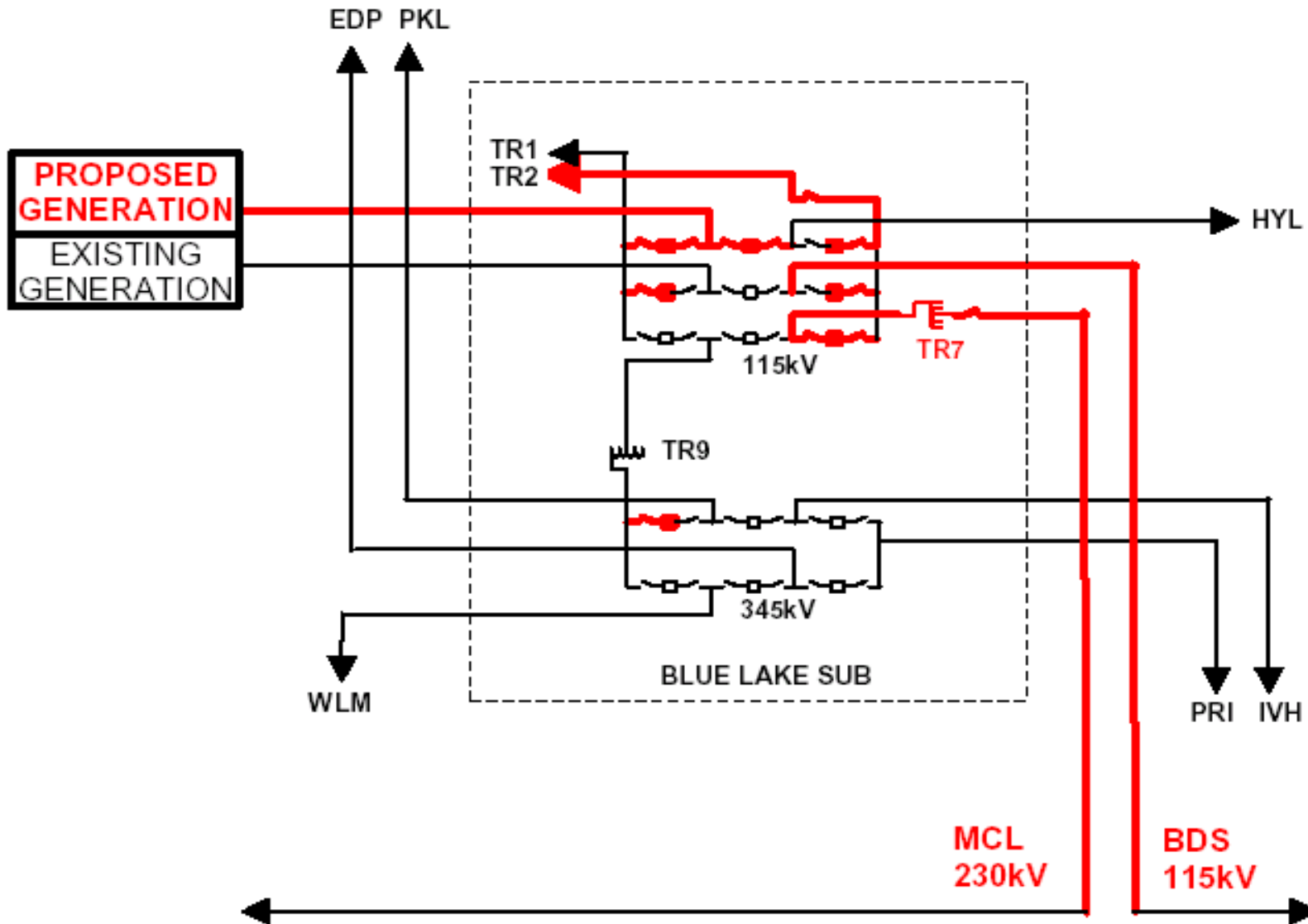

# New Koch to Inver Hills 115 kV #2

- **Need:**
  - Under summer peak conditions, existing Koch to Inver Hills 115 kV may overload for  
Outage of Black Dog to Riverwood 115 kV line
- **Solution:**
  - Build 2<sup>nd</sup> Inver Hills to Koch Refinery 115 kV along with substation equipment upgrades at Inver Hills and Koch Refinery substations
  - 2007 expected in-service date

# New Koch to Inver Hills 115 kV #2

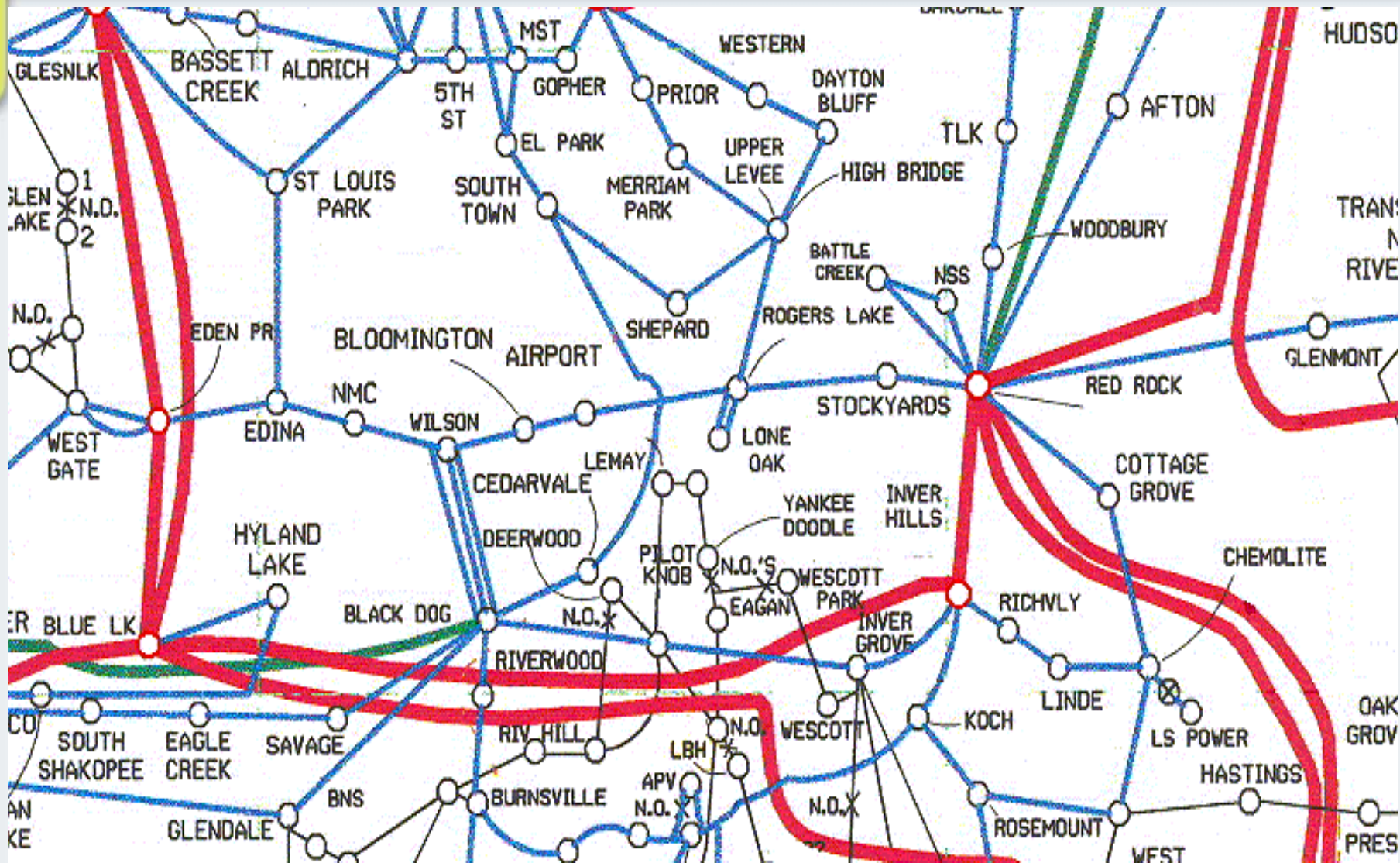

# Prairie Island to Red Rock 345 kV circuit #2

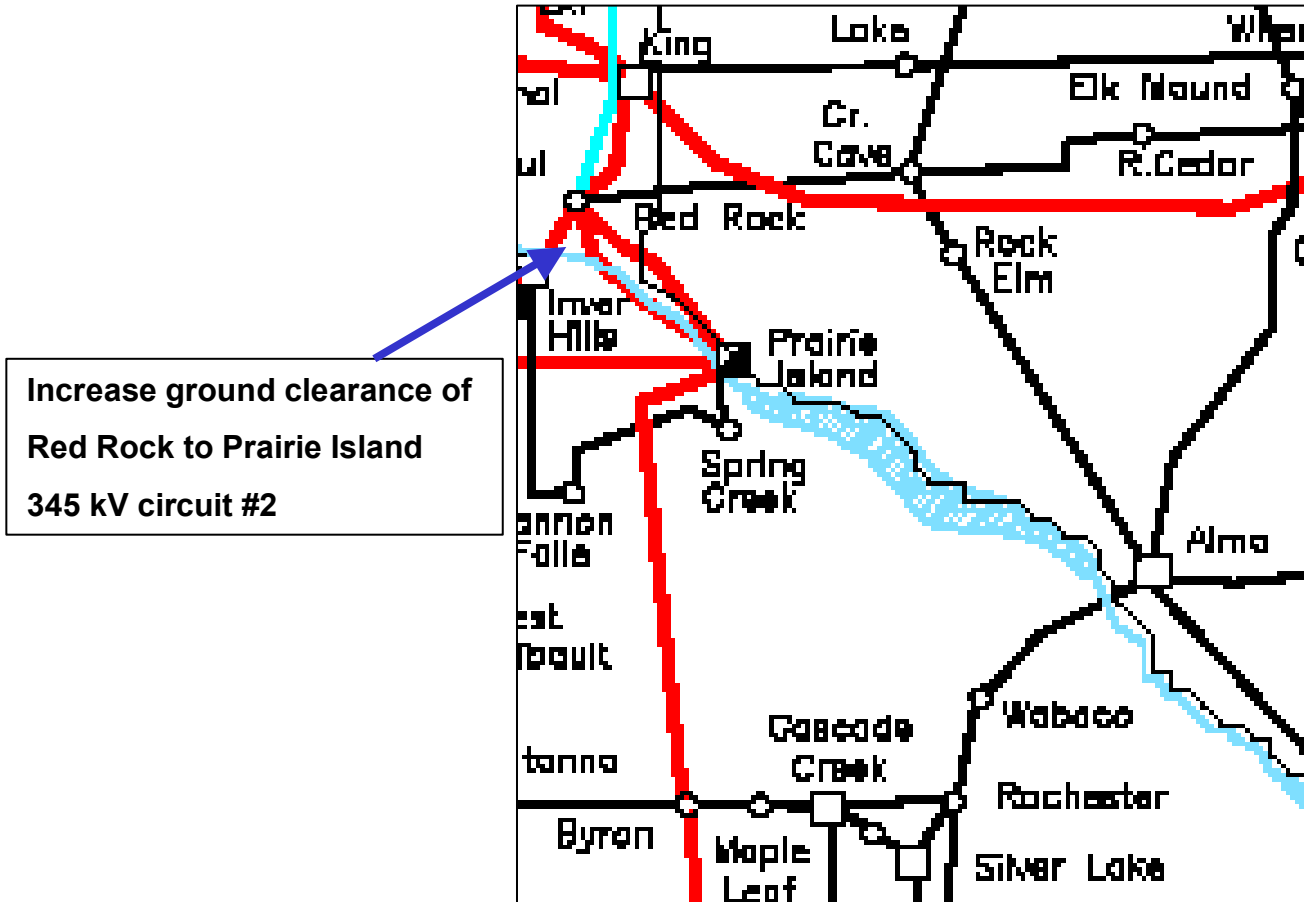

High Voltage Transmission to South and East of Twin Cities Metro

# Prairie Island to Red Rock 345 kV circuit #2 Uprate

- **Need:**

- One of the two parallel 345 kV lines build to an older standard
- Under some summer peak load conditions, this line may have insufficient ground clearance
- Outage of the double circuit from Blue Lake to Prairie Island and parallel Prairie Island to Red Rock 345 kV line.

- **Solution:**

- Increase the line clearance
- Expected in-service of 2006

# Oakdale to Tanners Lake 115 kV

- **Need:**
  - Under some Summer peak load conditions, the line may overload
  - Outage of Red Rock to Woodbury 115 kV line
- **Recommendation:**
  - Upgrade 5 mile Oakdale to Tanners Lake 115 kV
  - Expect final decision in early 2006

# Oakdale to Tanners Lake 115 kV

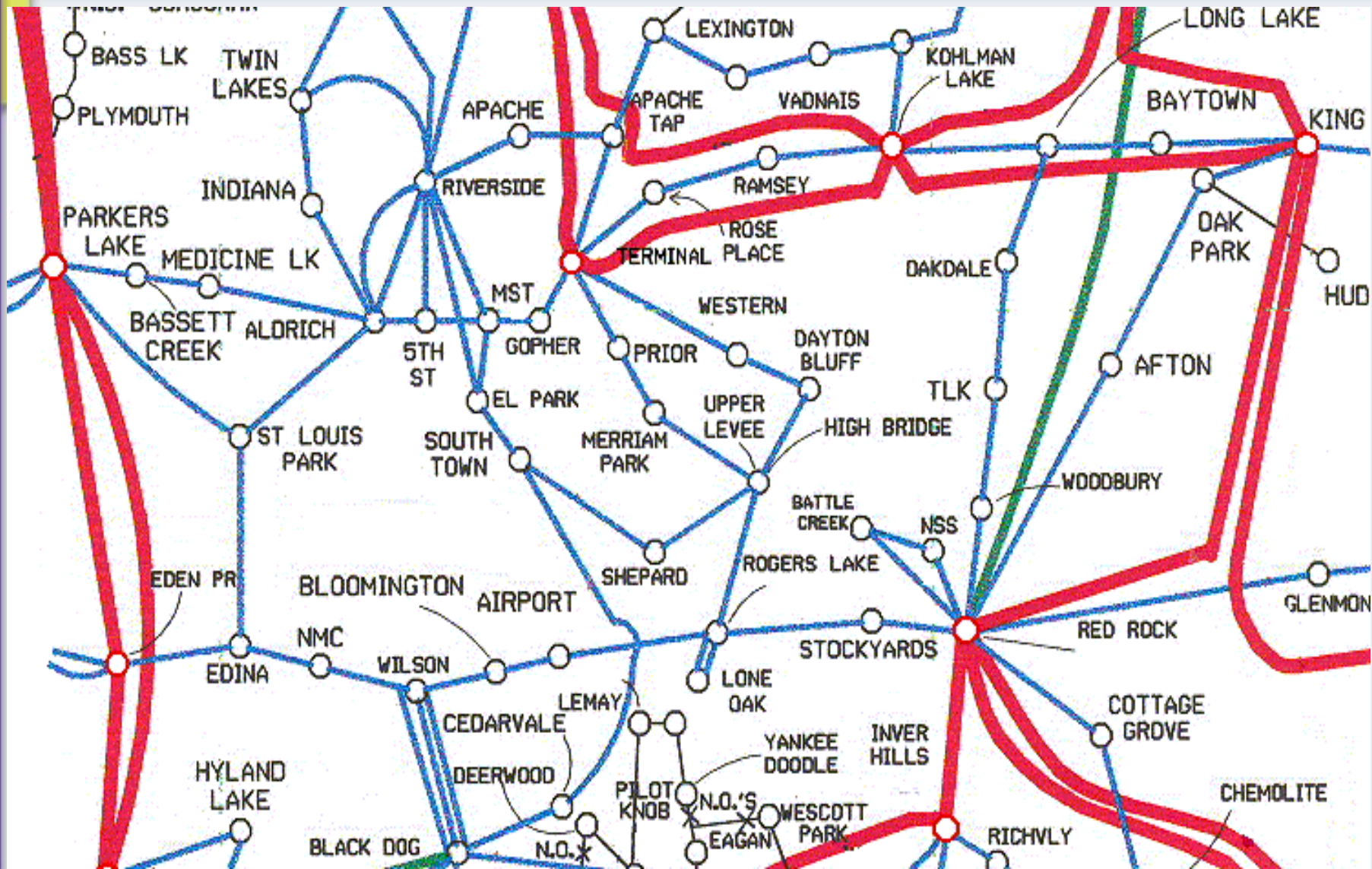

# Champlin to Champlin Tap 115 kV

- **Need:**
  - Under some Summer peak load conditions, the line may overload
  - Outage of the 345 kV double circuit Elm Creek to Parkers Lake line and the Sherburne County to Coon Creek 345 kV line
- **Recommendation:**
  - Upgrade capacity of 2.4 miles line in 2007
  - Expect final decision in early 2006

# Champlin to Champlin Tap

## 115 kV

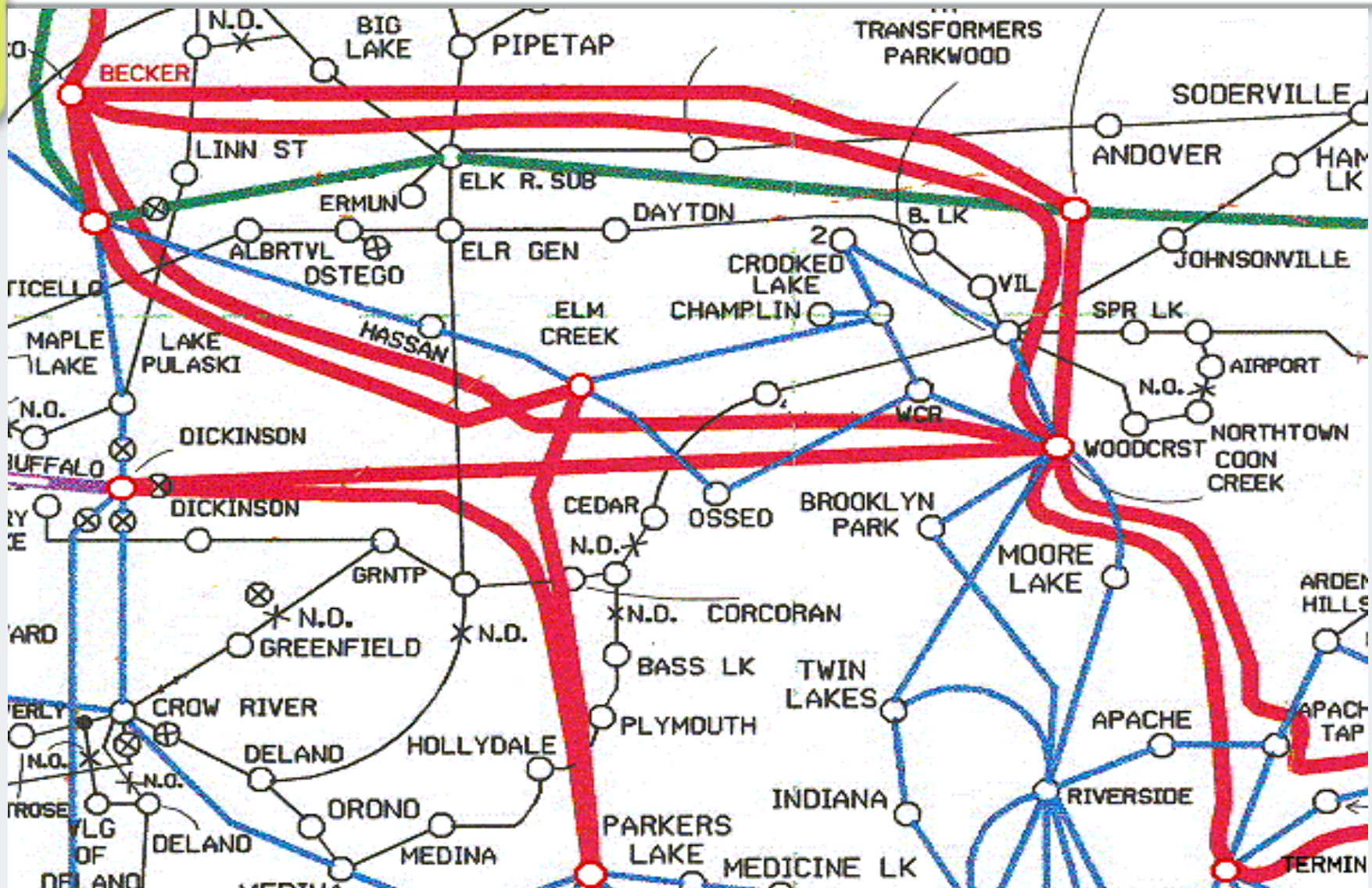

# Champlin Tap to Crooked Lake 115 kV

- **Need:**
  - Under some Summer peak load conditions, the line may overload
  - Outage of Coon Creek to Parkwood 115 kV
- **Recommendation:**
  - Upgrade capacity of 2.4 miles line in 2008
  - Expect final decision in early 2006

# Champlin Tap to Crooked Lake 115 kV

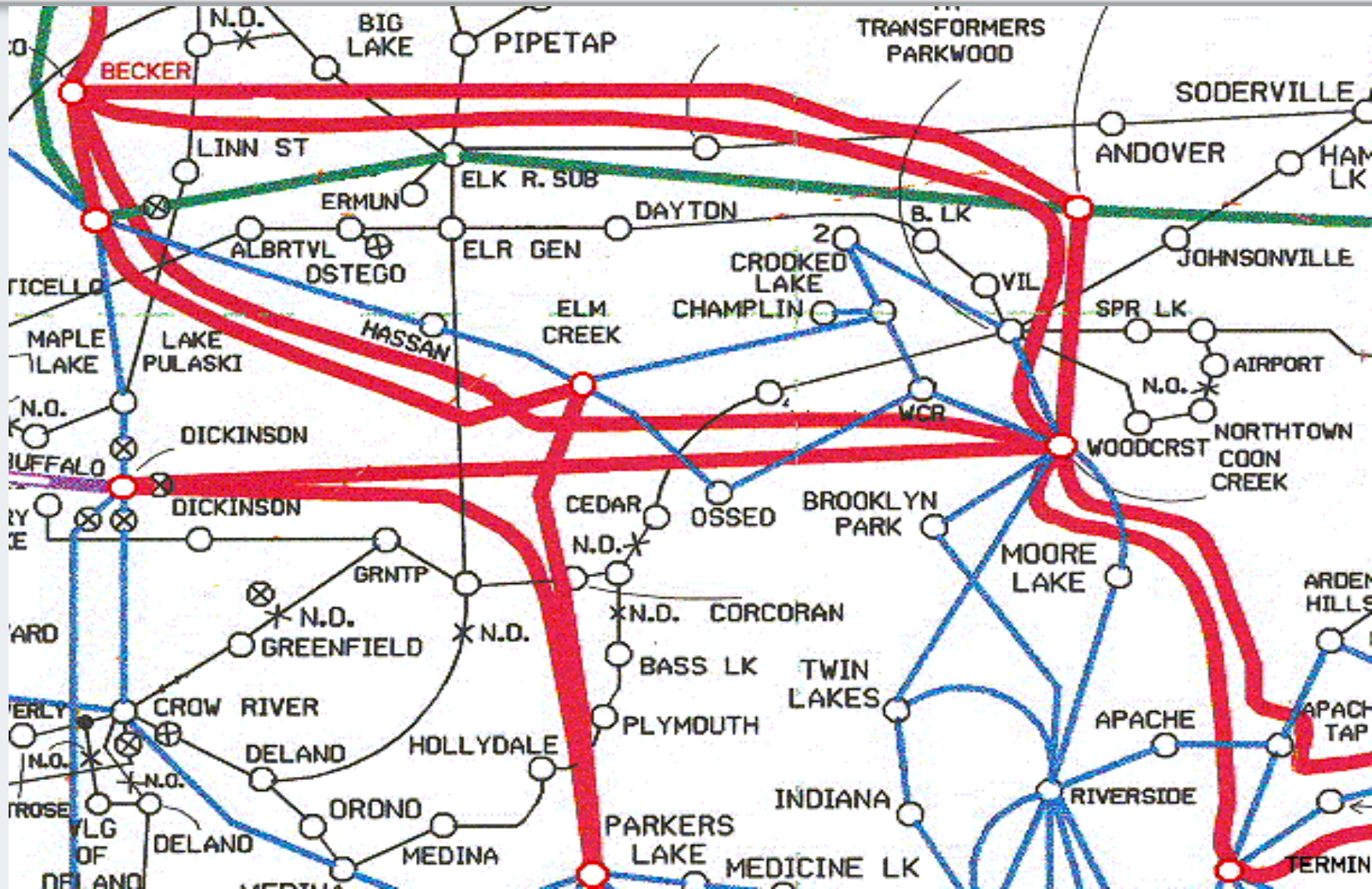

# New Yankee Doodle 115 kV source project-Existing Yankee Doodle area

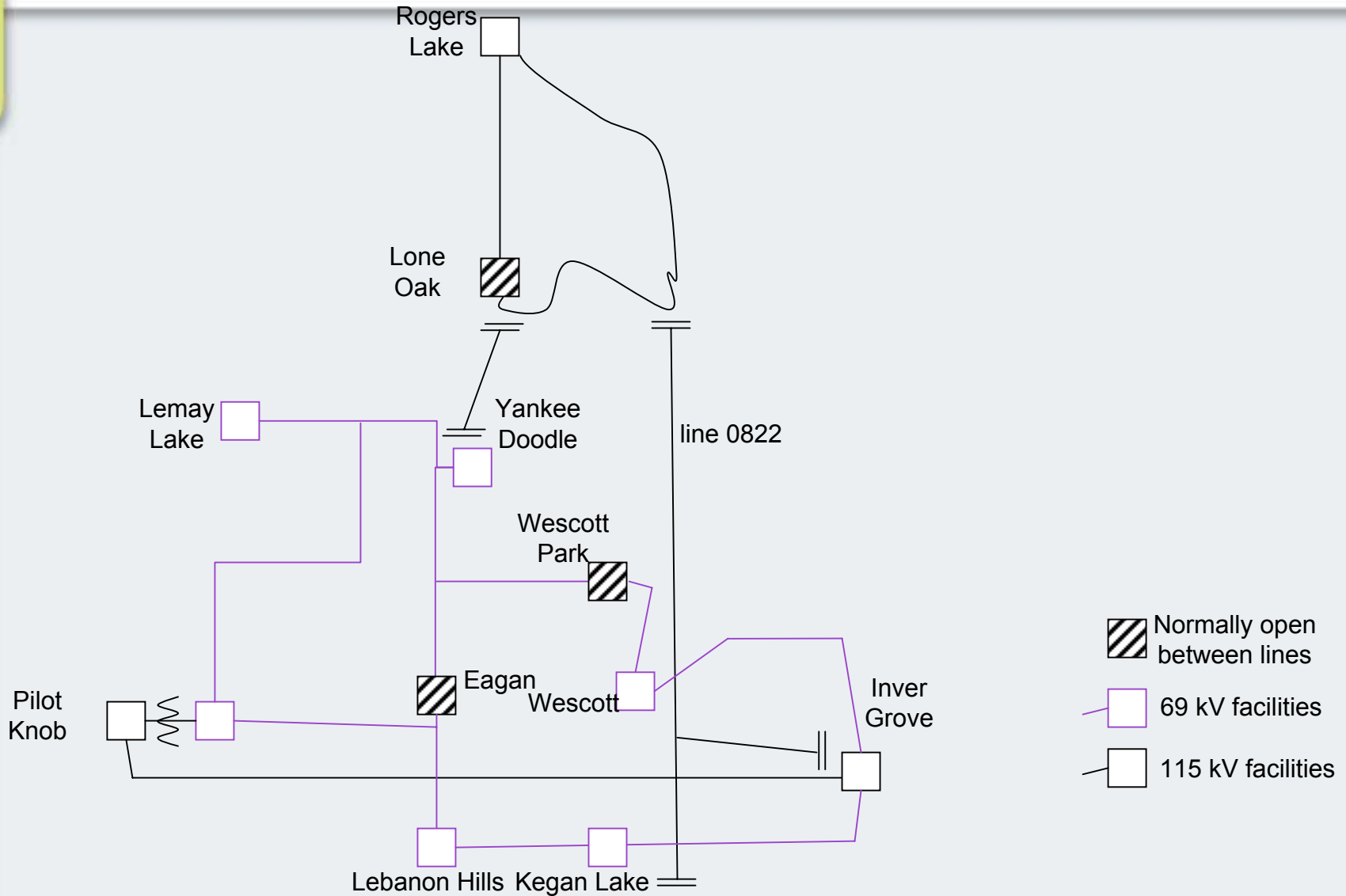

# Yankee Doodle served by single 115 kV from Lone Oak

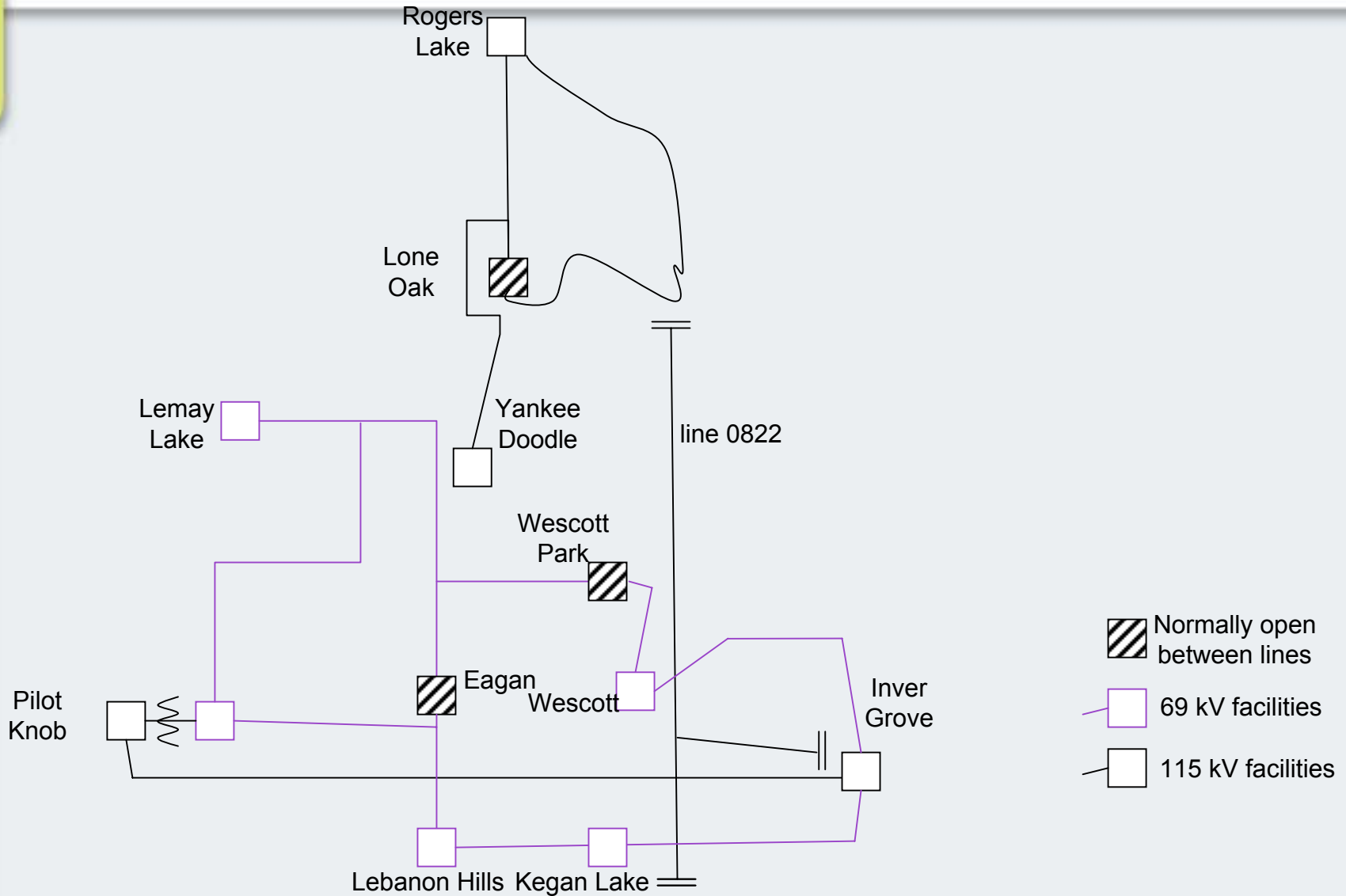

Twin  
Cities  
345/115  
kV Trans-  
formers

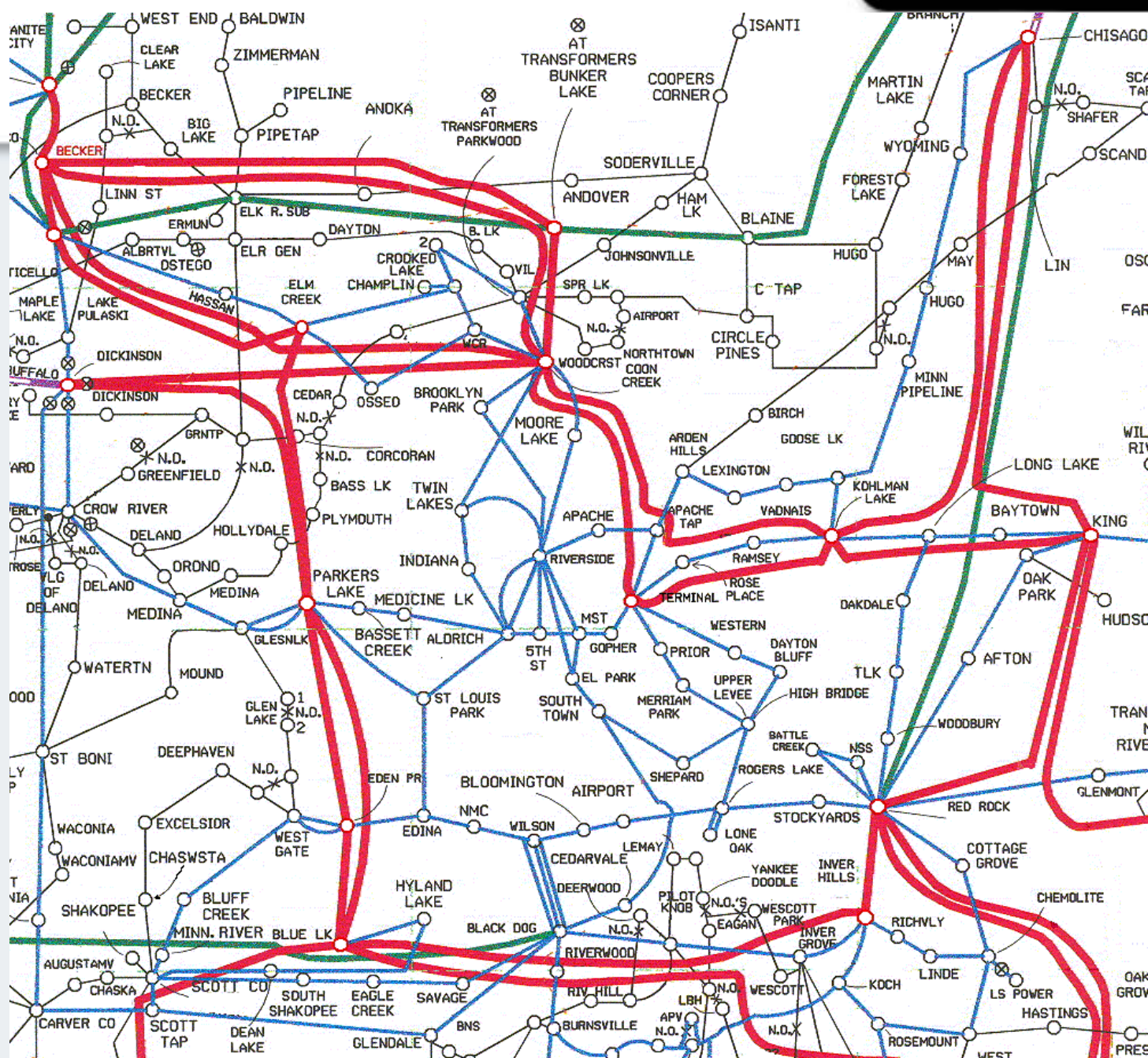

# Twin Cities 345/115 kV

## Transformers

- **Needs Identified:**
  - Under some summer peak conditions
    - Eden Prairie 345/115 kV may overload for parallel transformer outage
    - Parkers Lake 345/115 kV may overload for parallel transformer outage
    - Red Rock 345/115 kV may overload for parallel transformer outage
    - May be aggravated by reduced Twin Cities metro 115 kV generation levels.
- Twin Cities 10 year planning study expected to be initiated during 2005-2006.

# Twin Cities Fault Current Issue

- Need identified:
  - General fault levels on the system are increasing as we add lines and generation
  - The grounding capability is limited to 50 kA. This is due to grounding equipment limitations
  - The next limiting equipment are the breakers that are nominally rated for 63 kA but have been de-rated to below 60 kA
  - Sectionalizing the system may be needed to decrease the fault current levels
  - Planning study is needed to identify alternatives

**Any Questions/ Input?**