



Addendum to G522
Interconnection Feasibility Study Report
550 MW Coal Fired Generation
Portage County, Wisconsin

G522
MISO Queue #38503-01

October 14, 2005
American Transmission Company, LLC

Tom Dagenais
System Planning

Addendum

This addendum applies to the Interconnection Feasibility Study for the Midwest Independent System Operator (“MISO”) Generation Interconnection Request project #G522, MISO Queue #38503-01. The G522 generation is proposed to connect to Line L6831 [Rocky Run – Werner West (future) – North Appleton] at 345 kV.

Further analysis of the Summer 2011 base case was performed with the inclusion of competing generation from the MISO Queue that is located outside of the ATC footprint. Competing generation projects that have been included in the model are listed in Table AD-1.

Table AD-1: Competing Generation located outside of ATC footprint

Queue Number	Control Area	MW	Expected In-Service Year
G173	XCEL	300	2006
G237	XCEL	313	2008
G238	XCEL	125	2009
G261	XCEL	380	2006
G351	GRE	200	2007
G352	GRE	200	2009
G369	XCEL	385	2005
G389	GRE	178	2007
G390	GRE	92	2009
G428	XCEL	10	2006
G443	XCEL	19	2006
G444	XCEL	19	2007
G477	MP	531	2010

These generation increases in the model were offset by scaling down all generation of the control area in which each project is located. When compared to the original Summer 2011 peak case these changes resulted in a 56 MW increase in flow on the 345 kV circuit from King to Eau Claire and a 45 MW increase in flow on the 345 kV circuit from Eau Claire to Arpin.

Inclusion of these projects resulted in one additional injection limit for the requested interconnection. The new limit is the overload of the Hintz – Ellington 138 kV line for the loss of the N. Appleton – Werner West 345 kV line. AC verification of this constraint shows post-contingent loading at 300.7 MVA with a 293 MVA limit (102.6% loading). No other new limits were discovered. The additional injection limit is resolved by the projects required in the original G522 Interconnection Feasibility Report. These projects have been listed below in Table AD-2.

Table AD-2: Transmission Projects relieving G522 injection limits

Project Description	Expected In-Service Year	Project Status
Construct Morgan – Werner West 345kV line	2009	Planned
String a new 138kV line from Clintonville to Werner West primarily on the Morgan – Werner West 345kV line structures	2009	Planned
Construct Gardner Park – Central Wisconsin 345kV line	2009	Planned



**Interconnection Feasibility Study Report
550 MW Coal Fired Generation
Portage County, Wisconsin**

**G522
MISO Queue #38503-01**

**October 6, 2005
American Transmission Company, LLC**

**Tom Dagenais
System Planning**

1. Summary

This report contains the results of the Feasibility Study for the Midwest Independent System Operator (“MISO”) Generation Interconnection Request project #G522, MISO Queue #38503-01. The purpose of this study is to identify steady state thermal and voltage violations caused by the proposed interconnection. The requested back-feed date for this project is November 1, 2010 and the requested in-service date is June 1, 2011.

The G522 generation is proposed to connect to Line L6831 [Rocky Run – Werner West (future) – North Appleton] at 345 kV. Figure 1 shows the existing transmission system including the future Werner West substation and the proposed G522 point of interconnection (“POI”) as well as the proposed projects in the immediate area that help to resolve injection constraints. The diagram shows one possible configuration and does not necessarily show the ultimate POI layout, nor does it necessarily reflect the future layout of the other substations depicted. The final interconnection will depend on the thermal, voltage, and stability analysis performed in the Feasibility Study and the Interconnection System Impact Study (“ISIS”) in addition to operational and physical requirements to support the interconnection.

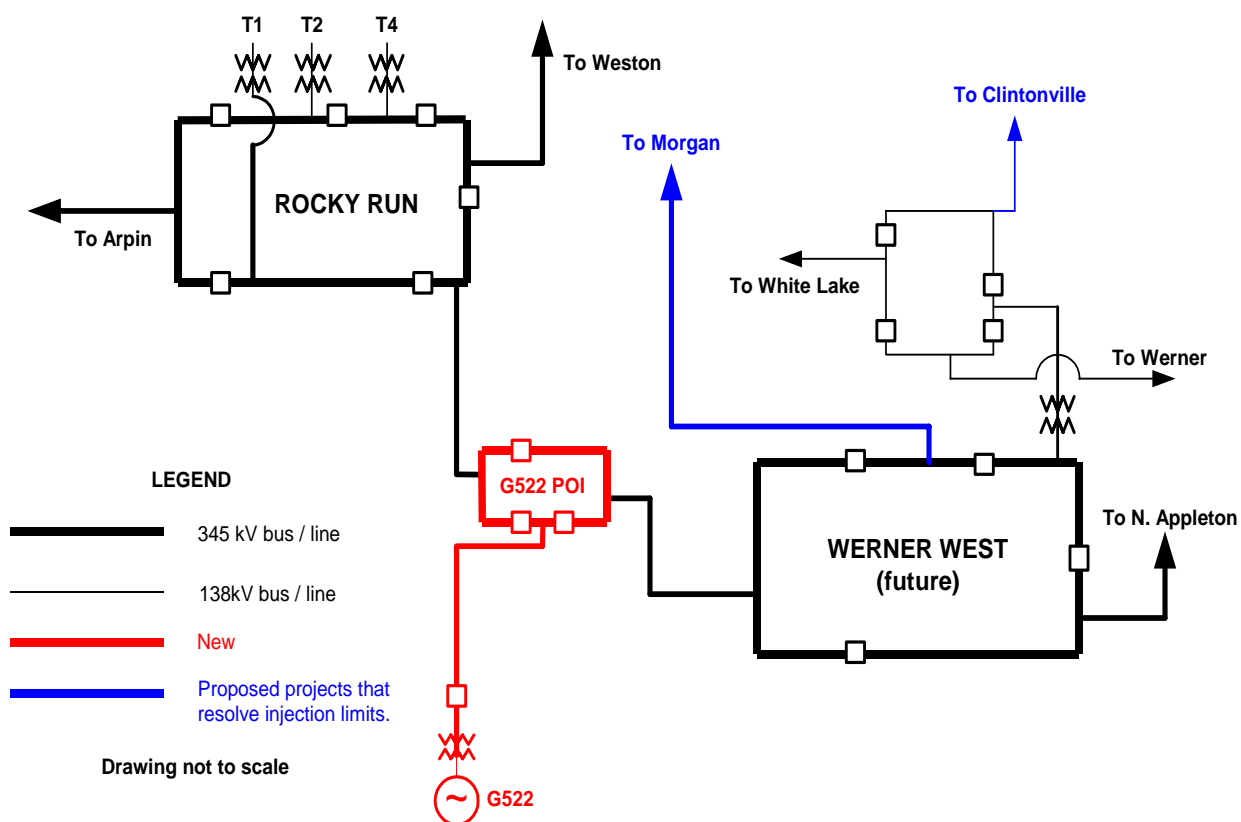

Figure 1: Possible G522 interconnection configuration

The study identified 21 steady-state NERC Category B Event thermal violations, three of which meet the criteria of injection limits and will require mitigation to acquire energy resource status. A total of 22 double contingency violations occurred requiring potential operating restrictions. The study initially identified two injection limits, but the inclusion of two planned projects in the study model to mitigate these limits led to the identification of an additional injection limit. Solutions to all three injection limits will be required to attain Energy Resource status for the full 550 MW of requested capacity. The limits are the future 138kV line Werner West – Werner, the 138kV Werner-Hintz tie, and the 345kV line from the G522 POI to Werner West. These limits are shown in Table A.1 in Appendix A.

A transfer sensitivity study was performed by sourcing 550 MW from G522 and delivering 275 MW to the Wisconsin Public Service (“WPS”) control area and 275 MW to the Alliant East (“ALTE”) control area. Performed on the base case without additional projects, the transfer sensitivity identified three additional post-contingent limits when compared to the thermal injection analysis. The newly identified limits are the 138kV Line I-113 (North Appleton – Lost Dauphin), the 138kV Line 80332 (Hintz – Ellington), and the Rocky Run 345/115 kV Transformer T2. Solutions to these limits are not required to attain Energy Resource status for the full 550 MW of requested capacity, but these limits indicate potential sources of congestion costs in the MISO Day 2 market.

The maximum allowable generation without system upgrades was found to be 212 MW based on injections limits to the system. Inclusion of the three planned projects that have been identified to resolve the injection limits (see Table 3.1) increases the maximum allowable generation to 550 MW as shown in Table A.2 in Appendix A. Total plant output may still be limited to zero MW when considering all identified constraints.

Voltage analysis determined that the existing system can support the G522 injection of 550 MW and maintain the 345 kV POI bus voltage above 0.97 per unit under first contingency conditions. Further reactive power analysis determined that the system is able to sustain the 345kV POI bus voltage of 1.02 per unit under contingency while using less than 50% of the modeled reactive power capability of G522. Results are listed in Table A.4 and Table A.5 in Appendix A.

Further Study

The next step in the Generator Interconnection Request process is for the Generator customer to decide whether to proceed with an ISIS. The ISIS will determine the system upgrades required to resolve all injection limits identified in this report and will include short circuit, transient and dynamic stability, and deliverability studies as applicable. Limits identified in the ISIS will also need to be resolved to obtain interconnection service. The ISIS will also determine the final interconnection configuration at the G522 substation and POI.

Required Interconnection Facilities

To be determined in the ISIS.

Network Upgrades

To be determined in the ISIS.

Special Facility Requirements

To be determined in the ISIS.

Operation Restrictions

The double contingency analysis identified 23 operating restrictions on G522 due to thermal constraints. A summary of the operation restrictions on G522 under prior outage conditions is provided in Table B.1 in Appendix B.

2. Criteria, Methodology and Assumptions

2.1 Study Criteria

All relevant MISO-adopted NERC Reliability Criteria and the American Transmission Company (“ATC”) contingency criteria are to be met for both the thermal and voltage analysis. Details of the analysis criteria applied in this study can be found in the Appendix C.

2.2 Study Methodology

The results of this study are subject to change. The results of the Study are based on data provided by the Generator and other ATC system information that was available at the time the study was performed, and the injection study does not guarantee deliverability to the MISO energy market. If there are any significant changes in the generator and controls data, changes in earlier queue Generator Interconnection Requests, changes in related Transmission Service Requests, or changes to ATC transmission system development plans, then the results of this study may also change significantly; therefore, this request is subject to restudy. The Generator is responsible for communicating any significant generation facility data changes in a timely fashion to MISO and ATC prior to commercial operation.

2.2.1 Competing Generation Requests

ATC determined in its sole judgment that earlier queue position Generator Interconnection Requests G144 and G477 have impact on the G522 study results. These requests are considered as competing requests for the interconnection of this generator and were therefore included in each base case. G144 is a 550 MW coal fired generating facility located in Marathon County, WI. G477 is a 531 MW integrated gasification combined cycle generating facility located in Minnesota.

Public information related to Generator Interconnection Request queue can be found via the MISO web site at <http://oasis.midwestiso.org/documents/ATC/queue.html>

2.2.2 Linear Transfer Analysis and A.C. Power Flow Analysis Methods

Thermal overloads were identified using linear transfer analysis and then verified with AC solutions. The linear transfer analysis was used to evaluate the intact system, N-1, N-2 and certain ATC multiple contingency conditions. The linear transfer analysis utilized adjusted MW ratings to account for reactive power flows and a 5% transmission reserve margin (“TRM”). All AC solutions utilized actual equipment ratings minus 5% TRM with real and reactive line flows.

The linear transfer analysis was performed using the Linear Transfer Analysis modules of the Managing and Utilizing System Transmission-7.0 (MUST, Version 7.0) program from Power Technologies, Inc (PTI). All AC solutions were performed using the Power Flow module of the Power System Simulation/Engineering-29 (PSS/E, Version 29) program from Power Technologies, Inc (PTI). These programs are accepted industry-wide for power flow analysis.

2.2.3 Base Cases

2.2.3.1 Power flow analysis

Base cases used in the thermal and voltage analysis for this study were developed based upon the ATC summer peak 2005 model and the July 2005 build of MISO seasonal cases of winter peak 2010/11 and summer peak of 2011. Three cases were developed to model various loading scenarios. The cases created modeled the winter peak of 2010/11, a shoulder peak of 2011, and the summer peak of 2011. The ATC system was modified by updating all loads to the expected coincident peak value and including all planned and proposed projects through 2007 and all planned projects through 2008 as listed in the ATC Ten Year Assessment. The MISO seasonal cases are accessible through the MISO Extranet. The output of G522 was delivered to all on-line MISO generation, unless specified otherwise.

Power flow analysis includes evaluation of thermal violations with an intact system and under N-1 and N-2 contingencies.

2.2.3.2 Deliverability analysis

Deliverability analysis, required for G522 to attain Network Resource status, was not performed for this study. This will be performed in the ISIS.

2.3 Assumptions

2.3.1 Generation Facility Modeling

The G522 generation was modeled at 550 MW of real power output while controlling the 345kV POI bus voltage to 1.02 per unit for AC power flow analysis, voltage analysis, and reactive power analysis unless specified otherwise. The G522 generator and step-up transformer were modeled with a Generator Step-Up transformer connecting them to the G522 345kV POI. The final interconnection configuration of the generator site will be determined and reviewed in the ISIS.

3. Analysis Results

3.1 Power Flow Analysis Results

3.1.1 Voltage Analysis & Reactive Capability

Voltage analysis was performed by modeling G522 as a 550 MW, 0 MVAR generator at the 345kV POI bus. The 550 MW injection was transferred outside of the ATC footprint. The analysis determined that the existing system can support the G522 injection of 550 MW while maintaining the 345kV POI bus voltage above 0.97 per unit under contingency. Results are listed in Table A.4 in Appendix A.

Further reactive power analysis was performed by modeling G522 as a 550 MW PMax, 341 MVAR QMax generator at the 345kV POI bus. The 550 MW injection was transferred outside of the ATC footprint. This analysis determined that the system is able to sustain the 345kV POI bus voltage of 1.02 per unit under contingency while using less than 50% of the modeled reactive power capability of G522. Results are listed in Table A.5 in Appendix A.

3.1.2 Results of Single Contingencies (N-1)

Study of the 550 MW injection from G522 identified no steady-state thermal violations for NERC Category A events. Twenty violations for NERC Category B events were identified, showing post-contingent overloads on 16 unique transmission elements. Of these 20 violations, two transmission elements have been identified as injection limits. The resolution of these injection limits by the addition of planned projects to the model resulted in one more violation (see last row of Table A.1). This additional violation also met the criteria of an injection limit. This limit was resolved by the addition of one planned project to the model.

This analysis was performed on each base case and then on each base case plus the three projects listed in Table 3.1. The inclusion of these planned transmission projects eliminated all injection constraints. With the inclusion of projects from Table 3.1, an additional generation dispatch scenario was examined. In this scenario, referred to as “Summer-2 2011”, the system was further stressed by reducing counter-flow generation south of Green Bay and replacing it with generation north and west of G522 (50%) and from the Milwaukee area (50%). No additional injection limits were identified in this scenario.

Table 3.1: Transmission Projects relieving G522 injection limits

Project Description	Expected In-Service Year	Project Status
Construct Morgan – Werner West 345kV line	2009	Planned
String a new 138kV line from Clintonville to Werner West primarily on the Morgan – Werner West 345kV line structures	2009	Planned
Construct Gardner Park – Central Wisconsin 345kV line	2009	Planned

A transfer sensitivity study was performed on the base case without system upgrades, delivering 50% of the G522 output to WPS and 50% of the output to ALTE. The study found three violations in addition to those found in the injection analysis and small changes in the individual distribution factors (<1%) of previously identified limits. The newly identified violations are the 138kV Line I-113 (North Appleton – Lost Dauphin), the 138kV Line 80332 (Hintz – Ellington), and the Rocky Run 345/115 kV Transformer T2.

The maximum allowable real power output without system upgrades was determined by reducing G522 generation until all steady-state thermal violations due to G522 were resolved. The maximum allowable output without system upgrades was identified as 212 MW based on injection limits identified in the “Summer-2 2011” case. When taking all limits into account, the maximum allowable output without system upgrades is 0 MW. The maximum allowable output of G522 after inclusion of the three projects listed in Table 3.1 was identified as 550 MW based on injection limits. Violations that do not meet the criteria as injection limits still remain after inclusion of the three projects listed in Table 3.1. Results of the maximum allowable generation analysis can be found in Table A.2 in Appendix A.

For each of the violations identified in the N-1 analysis, a solution of limited scope is identified in the footnotes of Table A.1 in Appendix A. Solutions not identified in the ATC 10-Year Assessment are shown in Table 3.2 and were developed in the following order.

1. If the line is not limited by the conductor rating, then replace the terminal equipment.
2. If the line is limited by the conductor rating, then increase phase conductor clearance to the maximum operating temperature of the conductor.
3. If the maximum operating temperature of the conductor does not resolve the limit, then a line reconductor or rebuild is proposed.

Table 3.2: Potential Transmission Projects Resolving G522 N-1 violations

Limiting Element	Potential Solution
Bain – Kenosha 138kV Line 63151	Replace terminal equipment at the Kenosha 138kV substations
Rocky Run – Plover 115kV Line S-45	Increase the conductor clearance on line S-45, replace wave traps and jumpers
Rocky Run-Whiting Ave 115kV Line M-91	Replace jumpers within Whiting Ave 138kV substation
Port Edwards-Hollywood 138kV Line X-34	Replace jumpers within Port Edwards 138kV substation
Granville 345/138kV Transformer T3	Possibly replace low side current transformers
Arpin-Sigel 138kV Line X-33	Replace 138kV circuit breaker at the Sigel 138kV substation and jumpers at both Arpin and Sigel 138kV substations
Rocky Run 345/115 kV Transformer T1	No solution identified. Possibly replace unit with larger transformer.

The viability of each proposed solution cannot be assessed in the Feasibility Study. It may be possible that increasing the conductor clearance resolves the loading issue but is not physically or financially reasonable. Also, each solution is directly related to the individual constraint, it is possible that a separate plan may address all limits and offer secondary benefits such as relieving N-2 constraints. Solutions of this nature will be developed and examined in the ISIS.

3.1.2 Results of Double Contingencies (N-2)

Thermal and voltage constraints were evaluated for NERC Category C events (N-2 contingencies) in the electrical proximity of G522. The purpose of the N-2 analysis is to reveal potential violations and identify potential operating restrictions to eliminate the violations under prior outage conditions. The N-2 analysis was performed only on the summer peak model that included the projects listed in Table 3.1.

The double contingency constraints are not required to be resolved for the generator to attain either Energy Resource or Network Resource status. All identified operating restrictions will be reviewed in the ISIS as solutions are developed for NERC Category A and B violations.

Thermal violations under a selected number of N-2 contingencies were evaluated using linear transfer analysis. The N-2 analysis was performed using the “Summer 2011” model. The study identified numerous thermal violations as a result of local contingencies. The violations are listed in Table A.3 in Appendix A. The table includes all limiting elements that were identified in the N-1 analysis and lists only the most limiting double contingency for each.

The required operating restrictions for the double contingencies are listed in Table B.1 in Appendix B. The restrictions are based on the most limiting element, some of which were identified in the N-1 analysis (and were therefore included in Table A.3). These restrictions will be reviewed in the ISIS and a complete description of all N-2 limits and operating restrictions will be developed once the required solutions for N-1 limits are identified.

Appendix A

Power Flow Analysis Results

Table A.1 – Identified Thermal Violations due to G522 Delivery to MISO for N-1 Contingencies and ATC-defined multiple contingencies

Limiting Element	MVA Rating	N-1 MVA Loading	Worst Contingency	TDF (%)	Case Description	Injection Limit	Solution Proposed in TYA
Bain – Kenosha 138kV Line 63151	287	370	Pleasant Prairie – Zion 345kV Line 2221	4.7	Summer 2011 ¹	No	No ²
Rocky Run – Plover 115kV Line S-45	248	275	Rocky Run-Whiting Ave 115kV Line M-91	4.3	Summer 2011 ¹	No	No ³
Rocky Run-Whiting Ave 115kV Line M-91	277	305	Rocky Run – Plover 115kV Line S-45	4.8	Summer 2011 ¹	No	No ⁴
Granville 345/138 kV Transformer T3	478	508	Arcadian-Granville 345kV Line 9911 + Granville 345/138 kV Transformer T1	8.8	Summer 2011 ¹	No	Yes ⁵
Caroline-Belle Plaine 115kV Line J-36	119	133	G522 – Werner West 345kV Future Line	9.3	Summer 2011 ¹	No	Yes ⁶
Whiting Ave-Hoover 115kV Line H-138	246	244	G522 – Werner West 345kV Future Line	13.4	Summer 2011 ¹	No	Yes ⁶
Whitcomb-Caroline 115kV Line J-36	119	125	G522 – Werner West 345kV Future Line	7.9	Summer 2011 ¹	No	Yes ⁶
Kelly-Whitcomb 115kV Line J-36	165	175	G522 – Werner West 345kV Future Line	8.6	Summer 2011 ¹	No	Yes ⁶
Belle Plaine-Badger 115kV Line J-36	122	129	G522 – Werner West 345kV Future Line	9.2	Summer 2011 ¹	No	Yes ⁶
Arpin-Sigel 138kV Line X-33	287	290	Coyne-Baker West 115kV Line T-72	6.0	Summer 2011 ¹	No	No ⁷
Rocky Run 345/115 kV Transformer T1	192	187	Rocky Run 345/115 kV Transformer T4	3.6	Summer 2011 ¹	No	No ⁸
Werner West-Werner 138kV Future Line	287	313	Werner W.-N.Appleton 345kV Future Line	28.2	Summer 2011 ¹	Yes	Yes ⁶
Plover-Coyne 115kV Line J-114	180	186	Rocky Run-Coyne 115kV Line N-92	3.5	Summer 2011 ¹	No	Yes ⁶
Coyne-Baker West 115kV Line T-72	244	235	Arpin-Sigel 138kV Line X-33	6.2	Summer 2011 ¹	No	Yes ⁶
Ellington-Casaloma 138kV Line 80331	216	208	Werner W.-N.Appleton 345kV Future Line	12.9	Summer 2011 ¹	No	Yes ⁶
Werner-Hintz 138kV Line HN-Z-WER	287	281	Werner W.-N.Appleton 345kV Future Line	28.2	Summer 2011 ¹	Yes	Yes ⁹
G522 POI – Werner West 345kV Future Line	768	736	Kewaunee G1	48.6	Summer* 2011 ¹	Yes	Yes ⁶

* Indicates that this limit first occurs in the model that includes the Clintonville–Werner West 138kV line and Morgan–Central Wisconsin–Werner West 345kV line.

Notes:

1. Summer 2011, Shoulder 2011, and Winter 2010/11 represent the expected summer peak and shoulder peak of 2011 and winter peak of 2010-2011, respectively, including all planned projects through 2008 and proposed projects through 2007.
2. Thermal overload of the Bain – Kenosha 138kV line for the outage of the Pleasant Prairie – Zion 345kV line would require, at minimum, replacement of terminal equipment (i.e. relaying) at the Kenosha 138kV substation.
3. Thermal overload of the Rocky Run – Plover 138kV line for the outage of the Rocky Run – Whiting Ave 115kV line would require, at minimum, increasing the line conductor clearance to achieve a summer emergency operating temperature limit of 230°F, replacing a 1200 Amp wave traps at both Rocky Run and Plover and replacing jumpers at the Plover terminal. Bus conductor was not reviewed at either substation. The

- feasibility of increasing the conductor clearance has not been evaluated. A reconductor or rebuild of this line may be required.
4. Thermal overload of the Rocky Run – Whiting Ave 138kV line for the outage of the Rocky Run – Plover 138kV line would require, at minimum, replacing jumpers at the Whiting Ave substation to achieve a summer emergency rating of 1600 Amps. The feasibility of replacing the jumper has not been evaluated.
 5. Thermal overload of the Granville 345/138kV transformer would require, at minimum, replacement of one set of low side current transformers. Additionally, this limitation can be removed by the addition of the Mill Rd substation and 345/138kV transformer. The Mill Rd project has been proposed for completion in 2008 in the ATC 10-Year Assessment (TYA).
 6. Including the Clintonville – Werner West 138kV line, Morgan – Central Wisconsin – Werner West 345kV line, and Gardner Park – Central Wisconsin 345kV line projects in the model resolves this limit in all cases studied. These projects are currently before the Public Service Commission of Wisconsin for regulatory approval and appear in the ATC 10-Year Assessment (TYA).
 7. Thermal overload of the Arpin – Sigel 138kV line for the outage of the Baker West-Coyne 115kV line would require, at minimum, replacing the 1200 Amp circuit breaker at the Sigel substation and jumpers at both Arpin and Sigel. The feasibility of these changes has not been evaluated.
 8. The limitation is the rating of Rocky Run 345/138kV Transformer 1. Although no solution is identified, a potential solution may be the replacement of the transformer with a larger unit.
 9. Including the Cranberry – Conover – Plains 138kV project in the model resolves this limit in all cases studied. This project has been proposed for completion in 2008 in the ATC 10-Year Assessment (TYA).

Table A.2 – Maximum Allowable Generation With and Without System Upgrades¹

Injection Limiting Element	G522 Maximum MW	Worst Contingency	Model Description
Werner West-Werner 138kV Future Line	385	Werner W.-N.Appleton 345kV Future Line	Summer 2011
-	550	-	Summer 2011 w/ upgrades ²
Werner West-Werner 138kV Future Line	212	Werner W.-N.Appleton 345kV Future Line	Summer-2 2011
-	550	-	Summer-2 2011 w/ upgrades ²
Werner West-Werner 138kV Future Line	438	Werner W.-N.Appleton 345kV Future Line	Shoulder 2011
-	550	-	Shoulder 2011 w/ upgrades ²
Werner West-Werner 138kV Future Line	462	Werner W.-N.Appleton 345kV Future Line	Winter 2010/11
-	550	-	Winter 2010/11 w/ upgrades ²

Notes:

1. Based on injection limits. Only steady state analysis was considered, stability limitations will be considered in the ISIS.
2. Upgrades included in the models were the Clintonville – Werner West 138kV line, the Morgan – Central Wisconsin – Werner West 345kV line, and the Gardner Park – Central Wisconsin 345kV line.

Table A.3 – N-2 Contingency¹ results for previously identified Thermal Violations due to G522

Limiting Element ²	MVA Rating	Worst MW Loading	Double Contingency	TDF (%)	Solution Proposed in TYA
Rocky Run 345/115 kV Transformer T1	192	279	Rocky Run 345/115 kV Transformer T2 + Rocky Run 345/115 kV Transformer T4	5.4	No ³
Ellington-Casaloma 138kV Line 80331	216	249	Butte Des Morts – N.Appleton 138kV + N.Appleton – Apple Hills 138kV	4.1	No ⁴
Rocky Run-Whiting Ave 115kV Line M-91	277	324	G522 POI – Werner West 345 kV + Gardner Park – Central Wisconsin 345 kV	11.7	No ⁵
Whiting Ave-Hoover 115kV Line H-138	246	255	G522 POI – Werner West 345 kV + Gardner Park – Central Wisconsin 345 kV	13.3	No ⁶
Arpin-Sigel 138kV Line X-33	287	281	G522 POI – Werner West 345 kV + Gardner Park – Central Wisconsin 345 kV	7.9	No ⁷
Coyne-Baker West 115kV Line T-72	244	242	G522 POI – Werner West 345 kV + Arpin 345/138 kV Transformer T21	8.6	No ⁸
Caroline-Belle Plaine 115kV Line J-36	119	125	G522 POI – Werner West 345 kV + Gardner Park – Central Wisconsin 345 kV	9.7	Yes ⁹
Whitcomb-Caroline 115kV Line J-36	119	122	G522 POI – Werner West 345 kV + Gardner Park – Central Wisconsin 345 kV	8.3	Yes ⁹
Kelly-Whitcomb 115kV Line J-36	165	164	G522 POI – Werner West 345 kV + Gardner Park – Central Wisconsin 345 kV	8.8	Yes ⁹
Belle Plaine-Badger 115kV Line J-36	122	118	G522 POI – Werner West 345 kV + Gardner Park – Central Wisconsin 345 kV	9.7	Yes ⁹

Notes:

1. N-2 analysis of transmission elements in the electrical proximity of G522 performed using the Summer 2011 system peak model including the three projects listed in Table 3.1.
2. Because these limiting elements were identified as a single contingency limits, only the worst double contingencies are shown for each limiting element.
3. A solution for the thermal overload of the Rocky Run 345/138kV Transformer 1 for the outage of the Rocky Run 345/138kV Transformer T4 has not been identified. See Table A.1, Note 8.
4. Thermal overload of the Ellington - Casaloma 138kV line under double contingency can not be resolved by the projects described in Table A.1 Note 6.
5. Thermal overload of the Rocky Run – Whiting Ave 138kV line under double contingency can not be resolved by the projects described in Table A.1 Note 4.
6. Thermal overload of the Whiting Ave – Hoover 115kV line under double contingency can not be resolved by the projects described in Table A.1 Note 6.
7. Thermal overload of the Arpin – Sigel 138kV line under double contingency can not be resolved by resolved by the projects described in Table A.1 Note 7.
8. Thermal overload of Coyne – Baker West 115kV line under double contingency can not be resolved by the projects described in Table A.1 Note 6.
9. Including the Cranberry – Conover – Plains 138kV project in the model resolves this limit. This project has been proposed for completion in 2008 in the ATC 10-Year Assessment (TYA).

Table A.4 – Voltage analysis of G522 without proposed system upgrades¹

G522 Scenario	Contingency	G522 19kV Bus Voltage (pu)	G522 345kV Bus Voltage (pu)	Werner West 345kV Bus Voltage (pu)	Rocky Run 345kV Bus Voltage (pu)
550 MW / 168 MVAR	Intact system	1.0356	1.0200	1.0002	1.0196
550 MW / 0 MVAR	Intact system	1.0000	1.0032	0.9918	1.0044
550 MW / 0 MVAR	G522 POI - Rocky Run 345kV	0.9721	0.9757	0.9794	1.0111
550 MW / 0 MVAR	G522 POI – Werner West 345 kV	0.9981	1.0013	0.9848	1.0013

Notes:

1. Voltages of system buses while injecting 550 MW at G522. G522 MW output dispatched outside of ATC footprint (75% Illinois, 25% Minnesota). Analysis performed on 2011 Summer Peak case including all planned projects through 2008 and all proposed projects through 2007.

Table A.5 – Reactive power analysis of G522 without proposed system upgrades¹

Contingency	G522 MVAR Output	Percent of QMax of unit	G522 19kV Bus (pu)	G522 345kV Bus (pu)	Werner West 345kV (pu)	Rocky Run 345kV (pu)
Intact system	168.4	49.4	1.0449	1.0200	0.9997	1.0188
G522 POI - Rocky Run 345kV	108.8	31.9	1.0352	1.0200	0.9993	1.0117
G522 POI – Werner West 345 kV	134.2	39.4	1.0394	1.0200	0.9853	1.0174

Notes:

1. Reactive power necessary from G522 to keep G522 345kV POI at 1.02 per unit voltage. G522 modeled as 550 MW PMax, 341 MVAR QMax unit controlling G522 345kV POI to 1.02 per unit voltage. Injecting 550 MW at G522, output dispatched outside of ATC footprint (75% Illinois, 25% Minnesota). Analysis performed on 2011 Summer Peak case including all planned projects through 2008 and all proposed projects through 2007.

Appendix B

Summary of Operation Restrictions

Table B.1 – Summary of Identified Operation Restrictions on G522 due to N-2 Thermal Constraints¹

Prior outage	Allowable MW Output	Worst Next Contingency	Most Limiting Element	MVA Rating
Amberg – Plains 138kV	0	Dead River – Plains 345kV	Plains 345/138kV Transformer T1	250
Dead River – Plains 345kV	0	Amberg – Plains138kV	Plains 345/138kV Transformer T1	250
Falls – Pioneer 138kV	0	Dead River – Plains 345kV	Plains 345/138kV Transformer T1	250
Rocky Run 345/138 kV Transformer T2	0	Rocky Run 345/138 kV Transformer T4	Rocky Run 345/138 kV Transformer T1	192
Rocky Run 345/138 kV Transformer T4	0	Rocky Run 345/138 kV Transformer T2	Rocky Run 345/138 kV Transformer T1	192
Morgan 345/138 kV Transformer 1	0	Dead River – Plains 345kV	Plains 345/138kV Transformer T1	250
Rocky Run 345/138 kV Transformer T1	0	Rocky Run 345/138 kV Transformer T4	Rocky Run 345/138 kV Transformer T2	210
Arpin – Sigel 138kV	0	Rocky Run 345/138 kV Transformer T4	Rocky Run 345/138 kV Transformer T1	192
Butte Des Mortes – N.Appleton 138kV	0	North Appleton – Apple Hills 138kV	Ellington – Casaloma 138kV	216
North Appleton – Apple Hills 138kV	0	Butte Des Mortes – N.Appleton 138kV	Ellington – Casaloma 138kV	216
White Lake – Waupaca 138kV	0	Rocky Run 345/138 kV Transformer T4	Rocky Run 345/138 kV Transformer T1	192
G522 POI – Werner West 345kV	14	Gardner Park – Central Wisconsin 345kV	Rocky Run – Whiting Ave 115kV	277
Gardner Park – Central Wisconsin 345kV	14	G522 POI – Werner West 345kV	Rocky Run – Whiting Ave 115kV	277
Werner West – White Lake 138kV	316	G522 POI – Werner West 345kV	Rocky Run – Whiting Ave 115kV	277
Morgan – Plains 345kV	339	Kewaunee G1	Morgan – Falls 138kV	380
Kewaunee G1	339	Morgan – Plains 345kV	Morgan – Falls 138kV	380
North Appleton – Ellington 138kV	351	North Appleton – Fitzgerald 345kV	Butte Des Mortes 138 kV bus tie 1-2	287
North Appleton – Werner West 345kV	388	Morgan – Central Wisconsin 345kV	Werner West 345/138 kV Transformer 1	500
Morgan – Central Wisconsin 345kV	388	North Appleton – Werner West 345kV	Werner West 345/138 kV Transformer 1	500

Notes:

1. Additional operating restrictions may be identified in the ISIS due to stability analysis. N-2 contingencies were analyzed only in the Summer 2011 model. Each prior outage is listed only once along with its most limiting second contingency.

Appendix C

Study Criteria

Study Criteria

C.1 Contingencies

For stability analysis, a set of branches in the vicinity of the generator/power plant of concern is selected as contingencies, based on engineering judgment. Fault analysis is performed for the following six categories of contingency conditions:

1. Three-phase fault cleared in primary time with an otherwise intact system.
2. Three-phase fault cleared in delayed clearing time (i.e. breaker failure conditions) with an otherwise intact system.
3. Three-phase fault cleared in primary clearing time with a pre-existing outage of any other transmission element.
4. Single Line Ground (SLG) bus section fault cleared in primary clearing time with an otherwise intact system.
5. SLG internal breaker fault cleared in primary clearing time with an otherwise intact system.
6. SLG fault of double circuits on common tower cleared in primary time with an otherwise intact system.

For power flow analysis, contingencies include:

1. N-1 contingencies – all lines and transformers operated at 69kV and above in the following control areas/zones: ATC Planning Zones 1-5 and ties to those zones and all branches of voltage level 69kV and above in the Dairyland Power Cooperative, Northern States Power Control Area, Commonwealth Edison, and Alliant West control areas.
2. Selected N-2 and multiple contingencies that ATC has determined to be significant.

C.2 Monitored Elements

C.2.1 Intact System, N-1, N-2, and Special Multiple Contingency Evaluation Using Linear Transfer Analysis Method

All load carrying elements operated at 69kV and above in the following control areas/zones were studied: ATC Planning Zones 1-5, ties to those zones and all branches of voltage level 69kV and above in the Dairyland Power Cooperative, Northern States Power Control Area, Commonwealth Edison, and Alliant West control areas.

A Transmission Reliability Margin (TRM) of 5% was applied to all MVA ratings of monitored elements. Violations in this report are based upon the TRM adjustment of MVA ratings.

C.3 Thermal Loading Criteria

C.3.1 Injection Violations

Generation injection violations include 1) thermal violations of the transmission elements that connect the Generator to the rest of the transmission network (outlet congestion); 2) thermal violations of the transmission elements that have $TDF \geq 20\%$ anywhere in the studied system.

C.3.2 Operating Restriction Calculation

$$\text{Allowable Output} = \frac{\text{Equipment Rating} - [\text{Line Flow} - (\text{Generation Output} * \text{TDF})]}{\text{TDF}}$$

C.4 Steady State Voltage Criteria

C.4.1 Intact System, N-1 and Special Multiple Contingency Evaluation Using ACCC

Under intact system conditions, the voltage magnitude of all transmission system buses with a decrease of 0.01 per unit due to the Generator must not be lower than 0.95 per unit. Under contingency conditions, the voltage magnitude of all transmission system buses with a decrease of 0.01 per unit due to the Generator must not be lower than 0.90 per unit.

C.4.2 N-2 Contingency Evaluation

Power flow solutions must converge for a selected number of N-2 contingencies in the electrical proximity of the studied Generator. Divergence of a power flow solution indicates potential voltage collapse.

C.5 Stability Criteria

Critical Clearing Time (CCT) is a period relative to the start of a fault, within which all generators in the system remain stable (synchronized). CCT is obtained from simulation. Maximum Expected Clearing Time (MECT) determines a period of time that is needed to clear a fault using the existing system facilities. MECT is dictated by the existing system facilities. In any contingency, if the computed CCT is less than the MECT plus a margin determined by ATC (1.0 cycle in this study), it is considered an unstable situation and is unacceptable. Otherwise, it is considered acceptable stability performance.

In the context of stability analysis, voltages of all transmission system buses must recover to be at least 70% of the nominal system voltages immediately after fault removal and 80% of the nominal system voltages in 0.5 second after fault removal.